



US 20220196828A1

(19) **United States**

(12) **Patent Application Publication**
Sorrentino et al.

(10) **Pub. No.: US 2022/0196828 A1**

(43) **Pub. Date: Jun. 23, 2022**

(54) **RADAR REFERENCE MAP GENERATION**

(71) Applicant: **Aptiv Technologies Limited**,
St.Michael (BB)

(72) Inventors: **Aniello Sorrentino**, Wuppertal (DE);
Mohamed A. Moawad, Westfield, IN (US);
Nanhu Chen, Lafayette, IN (US);
Michael H. Laur, Mission Viejo, CA (US);
Jakub Porebski, Kraków (PL);
Amith Somanath, Woodland Hills, CA (US);
Aron Sommer, Köln (DE); **Kai Zhang**,
Carmel, IN (US); **Uri Iurgel**, Wuppertal (DE);
Alexander Ioffe, Bonn (DE); **Krzysztof Kogut**, Kraków (PL);
Ceyhan Karabulut, Oberhausen (DE);
Damjan Karanovic, Kamp-Lintfort (DE)

(21) Appl. No.: **17/367,295**

(22) Filed: **Jul. 2, 2021**

Related U.S. Application Data

(60) Provisional application No. 63/146,483, filed on Feb. 5, 2021, provisional application No. 63/127,049, filed on Dec. 17, 2020.

Publication Classification

(51) **Int. Cl.**
G01S 13/89 (2006.01)
G06N 7/00 (2006.01)
H04L 29/08 (2006.01)
(52) **U.S. Cl.**
CPC **G01S 13/89** (2013.01); **H04L 67/10**
(2013.01); **G06N 7/005** (2013.01)

(57) **ABSTRACT**
Methods and systems are described that enable radar reference map generation. A high-definition (HD) map is received and one or more HD map objects within the HD map are determined. Attributes of the respective HD map objects are determined, and, for each HD map object, one or more occupancy cells of a radar occupancy grid are indicated as occupied space based on the attributes of the respective HD map object. By doing so, a radar reference map may be generated without a vehicle traversing through an area corresponding to the radar reference map.

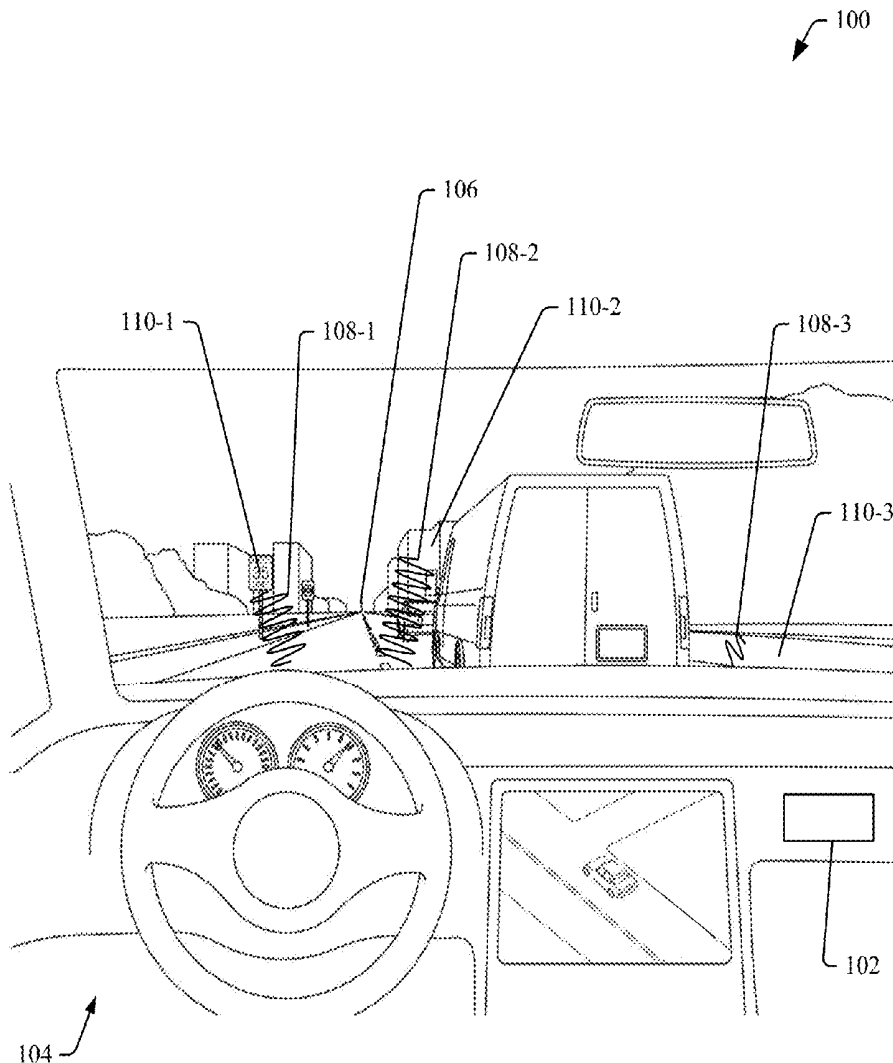

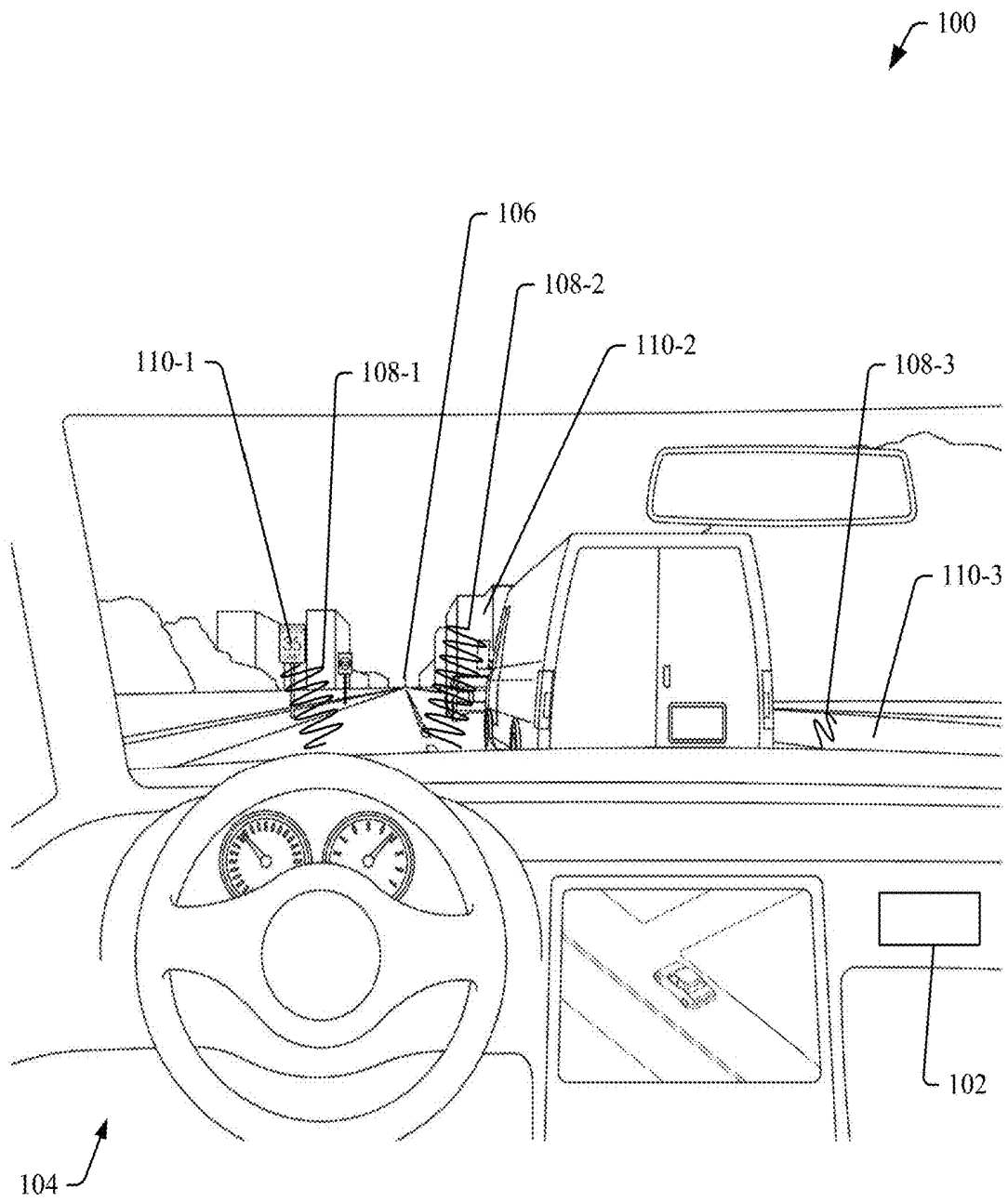

Fig. 1

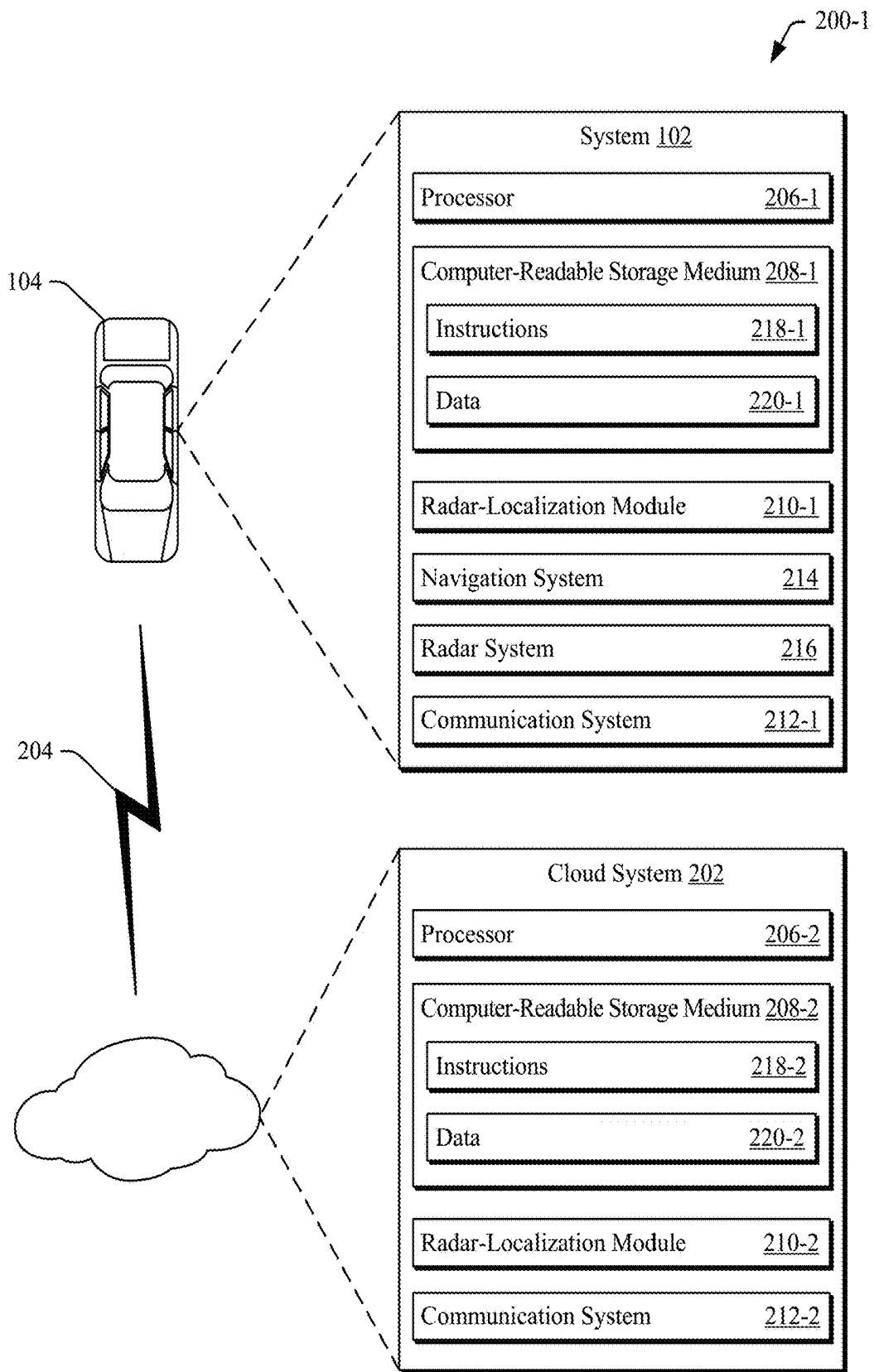

Fig. 2-1

200-2

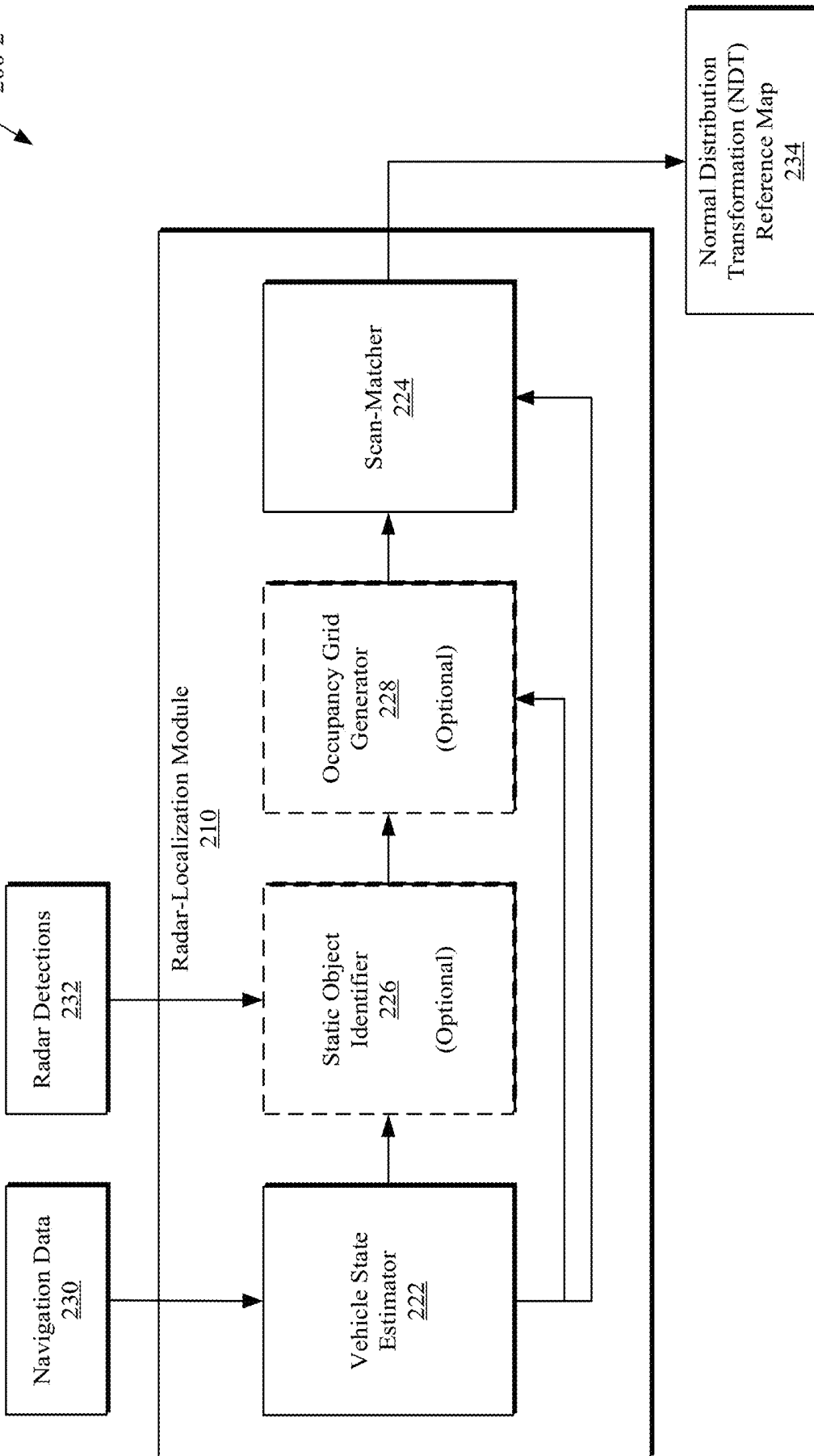

Fig. 2-2

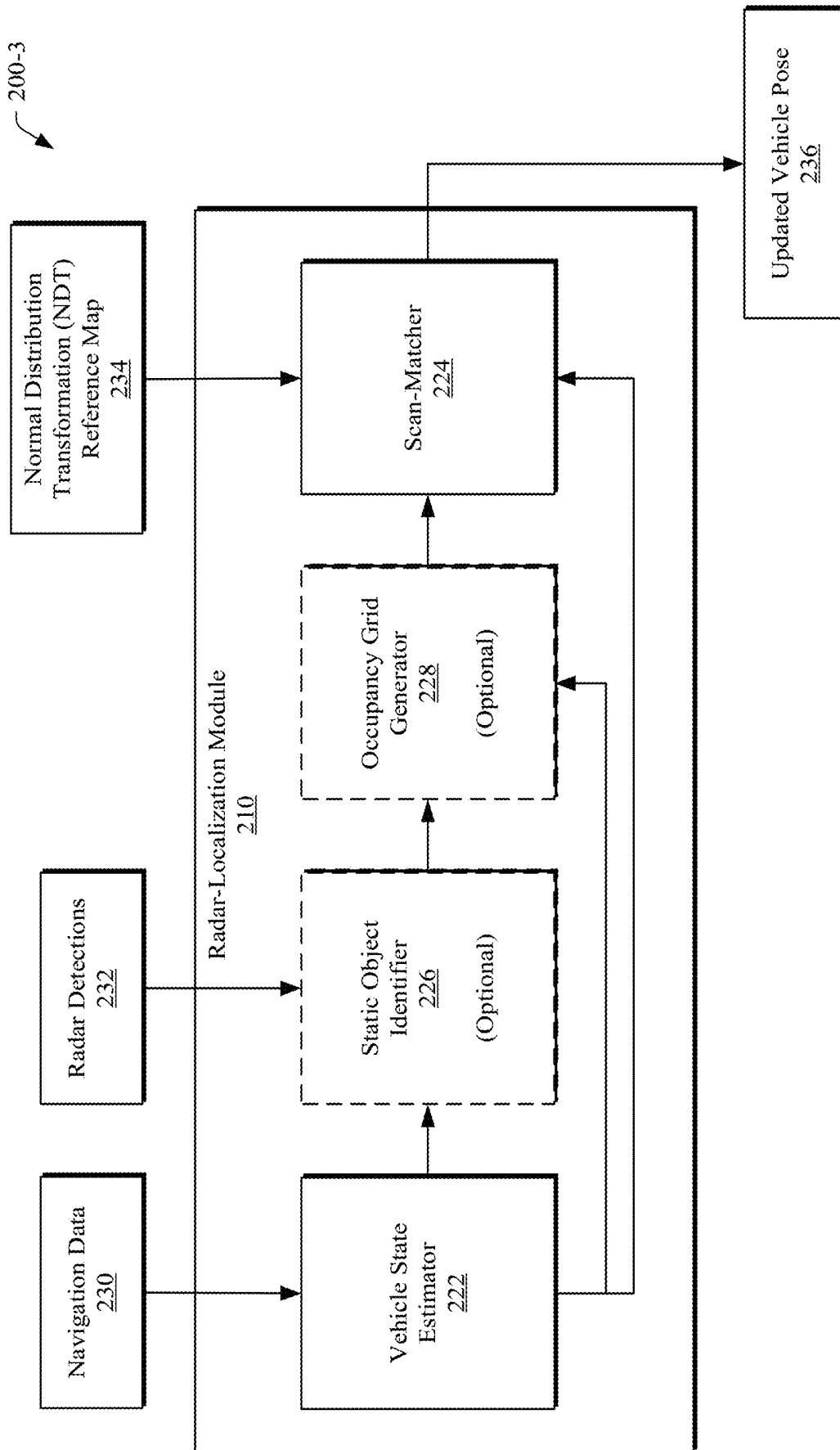

Fig. 2-3

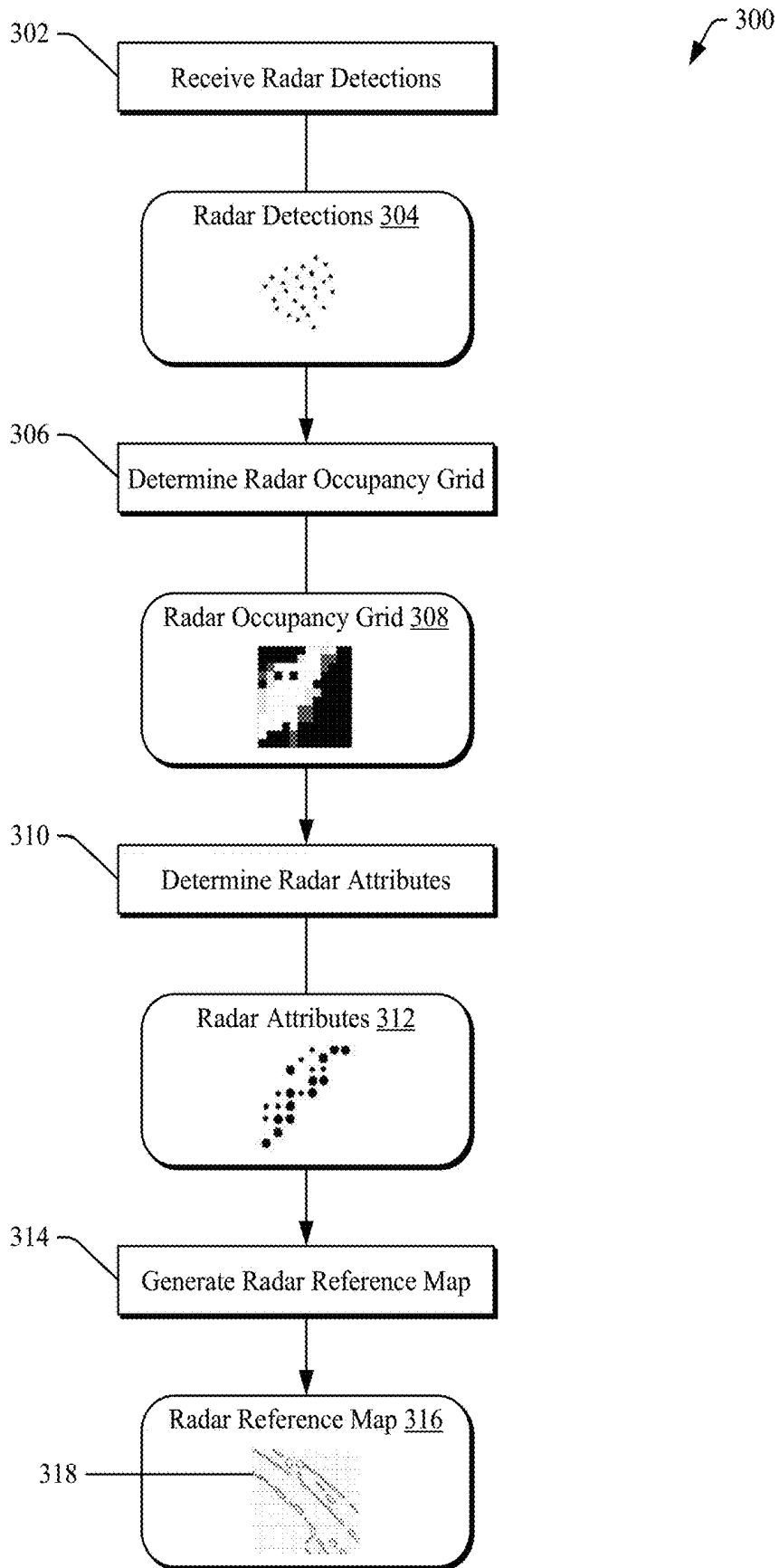

Fig. 3

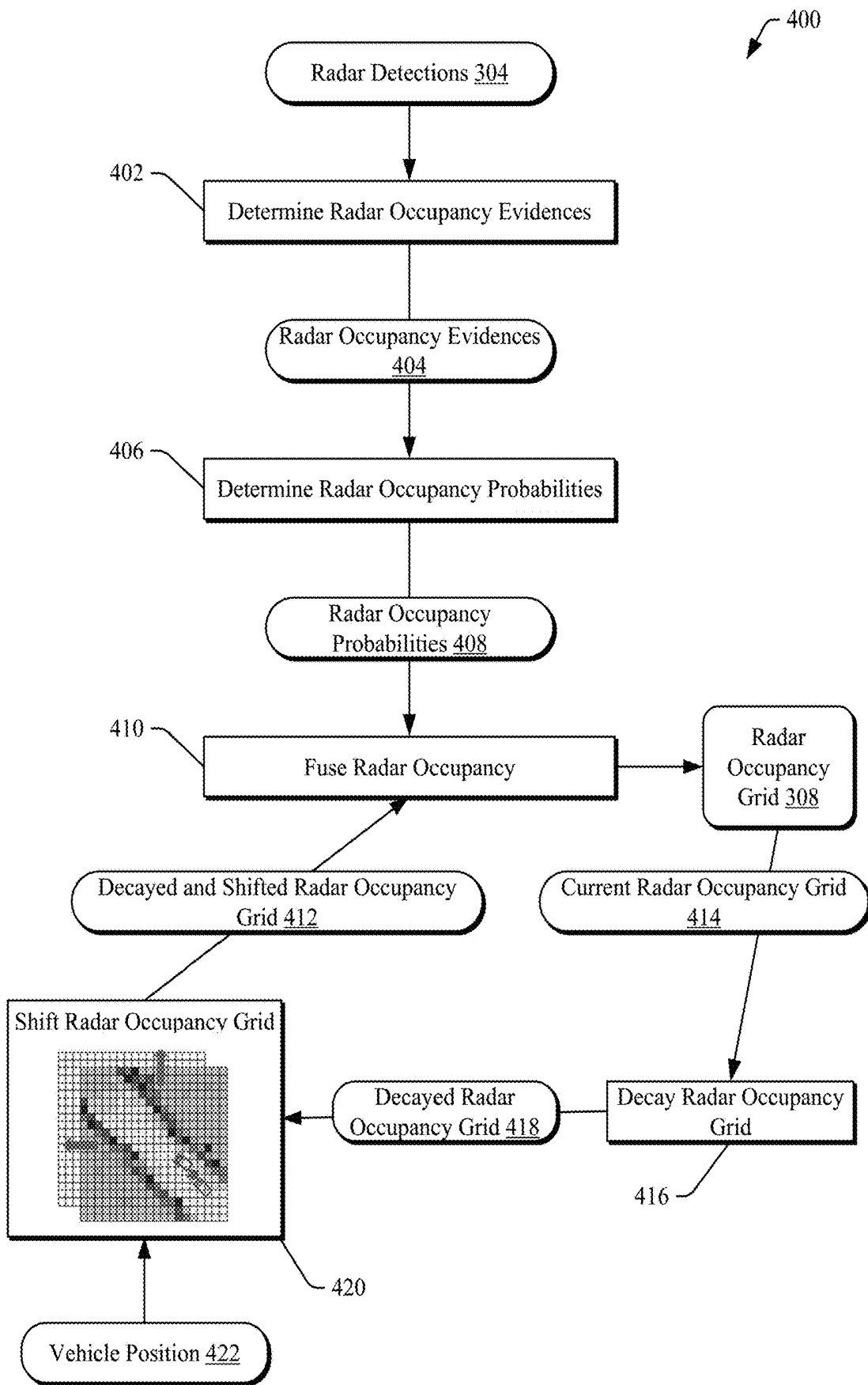

Fig. 4

500

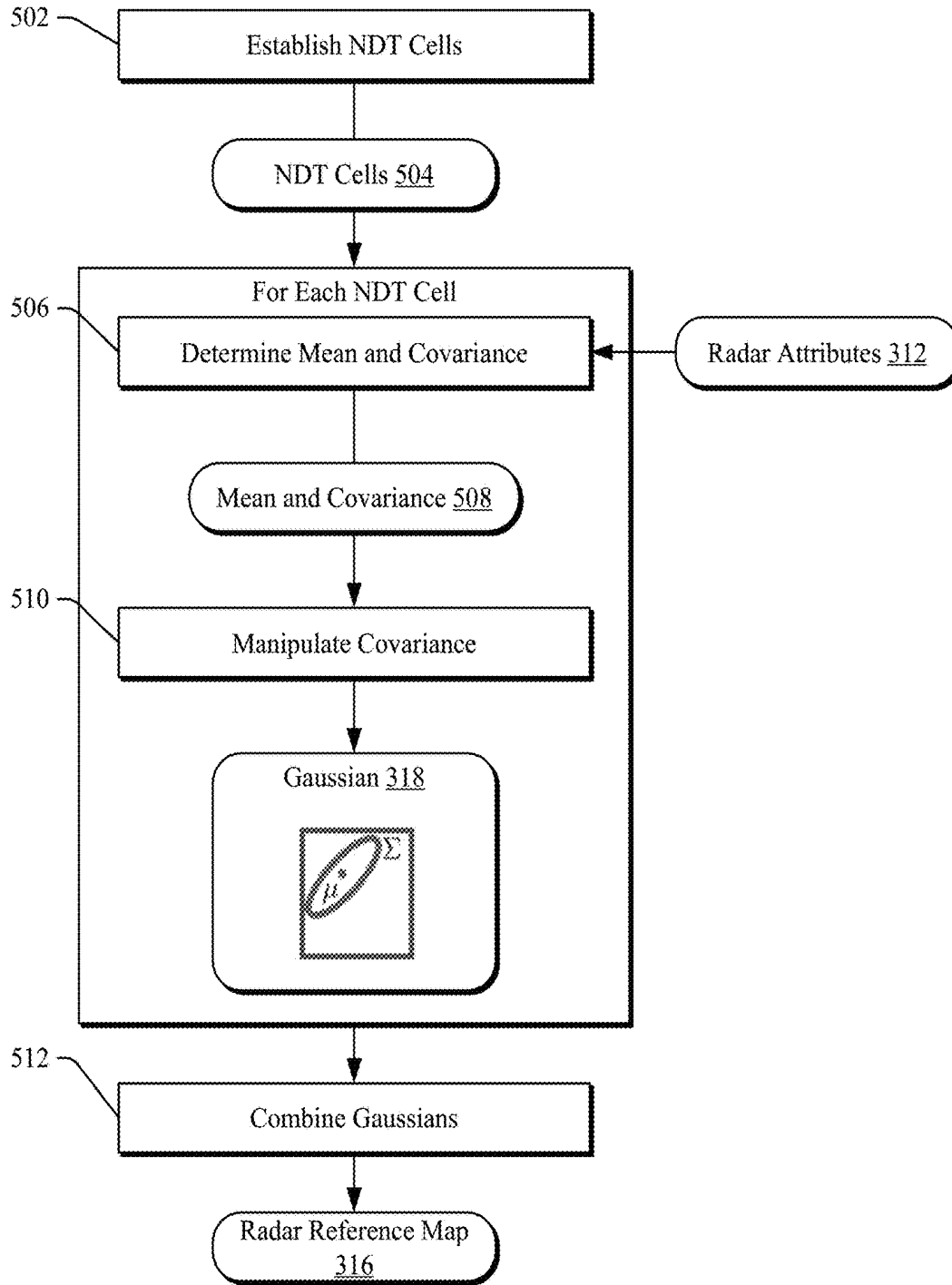

Fig. 5

600

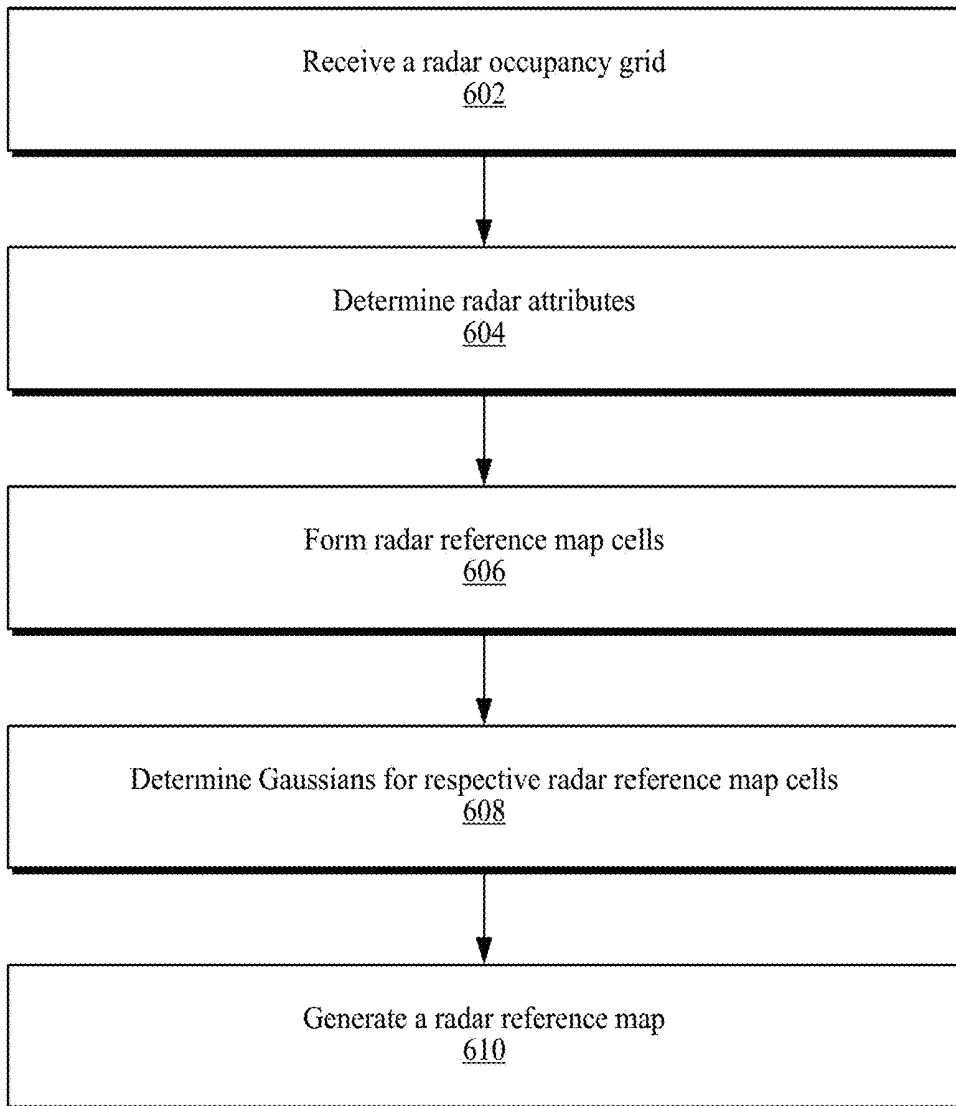

Fig. 6

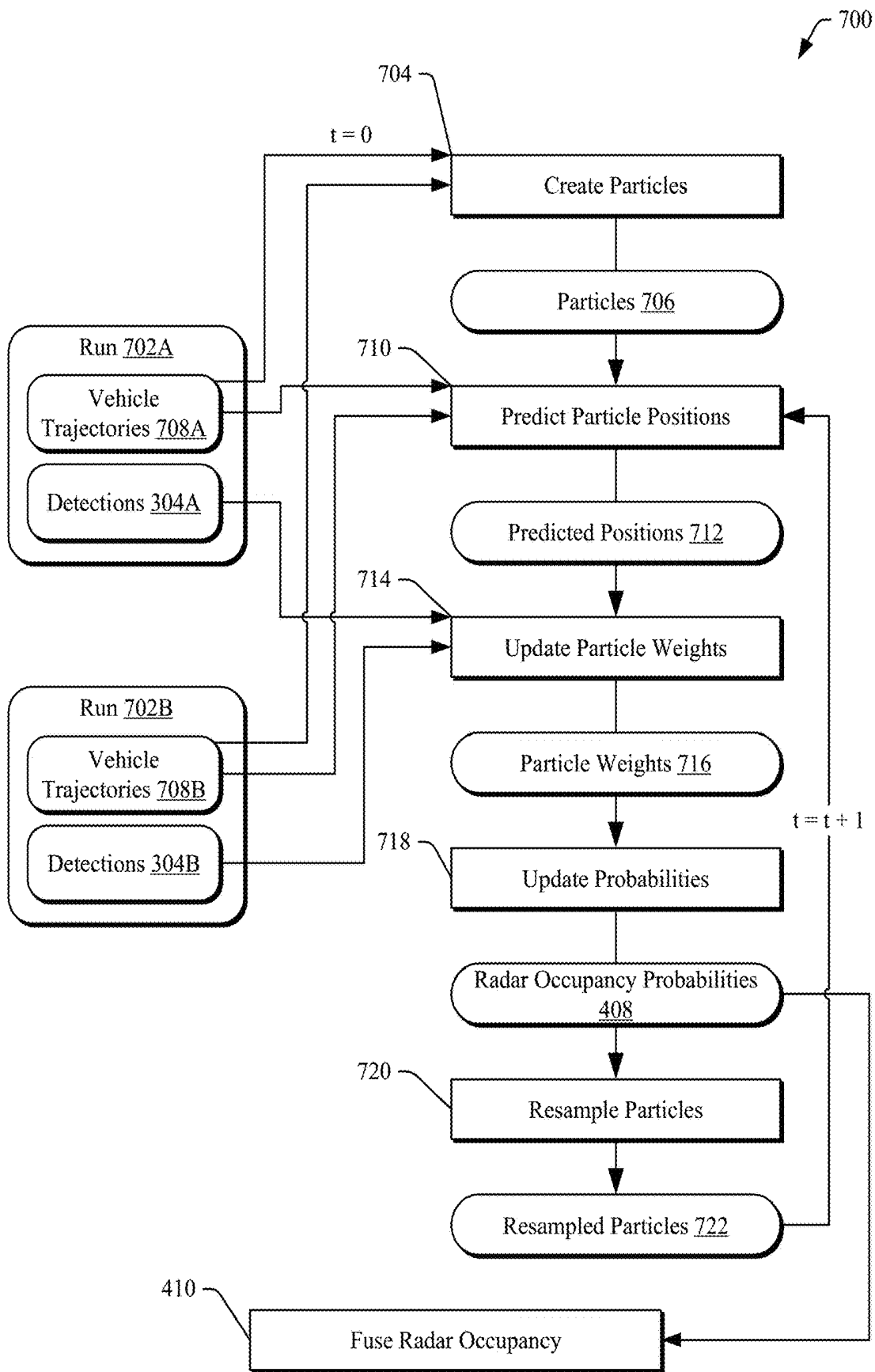

Fig. 7

800

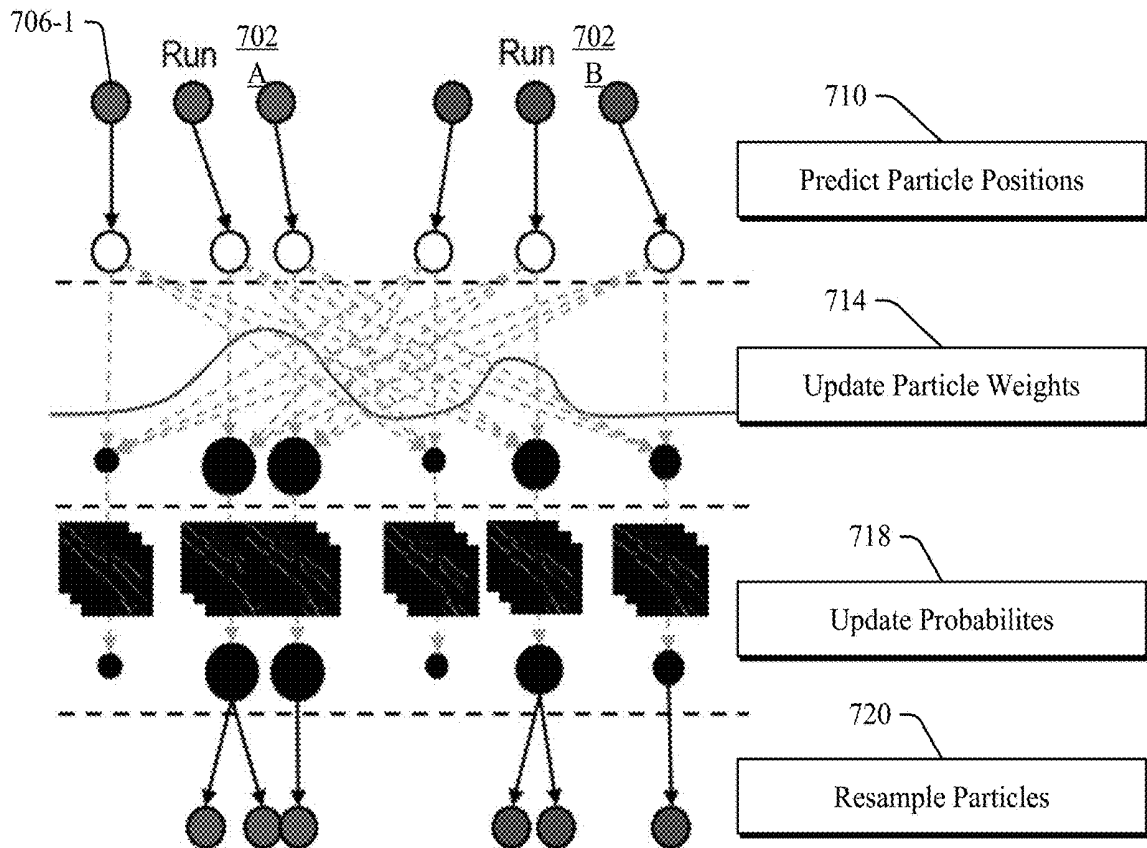

Fig. 8

900

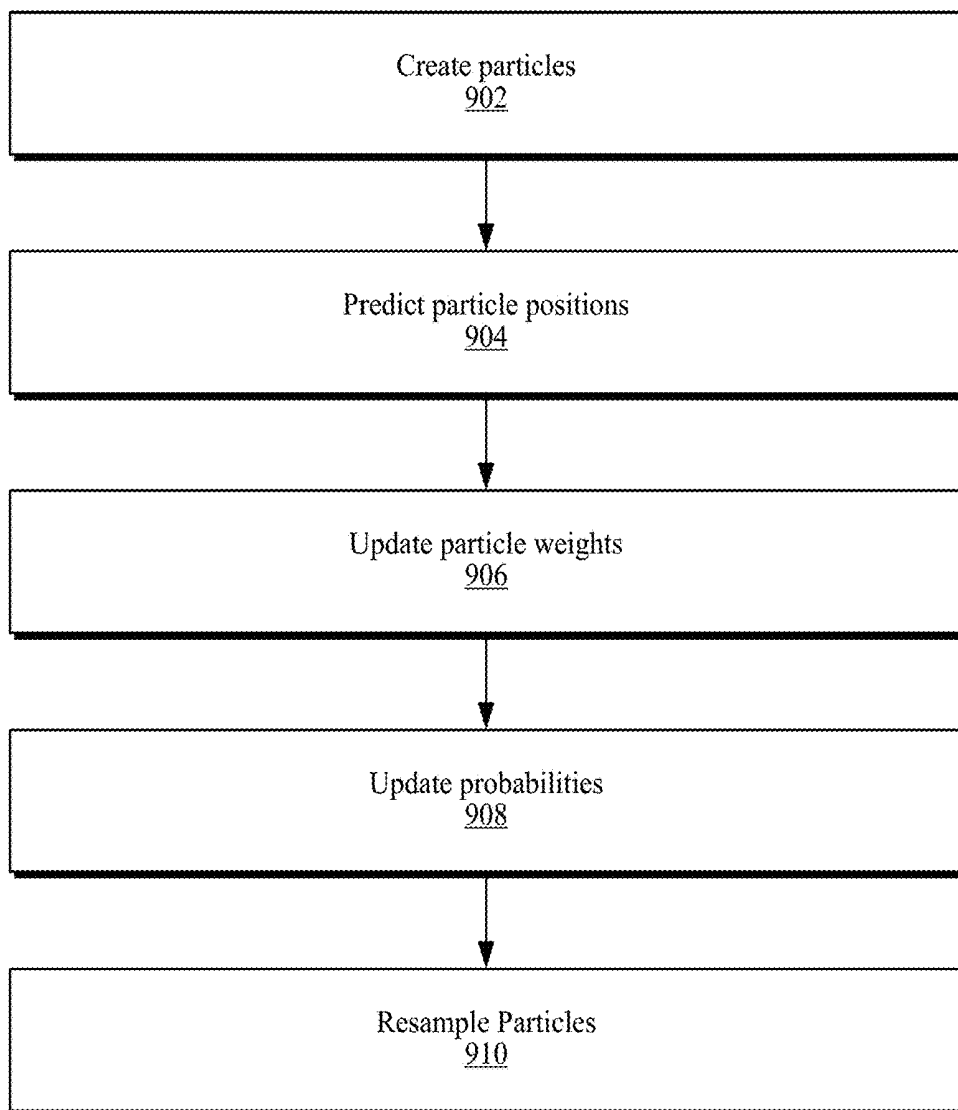

Fig. 9

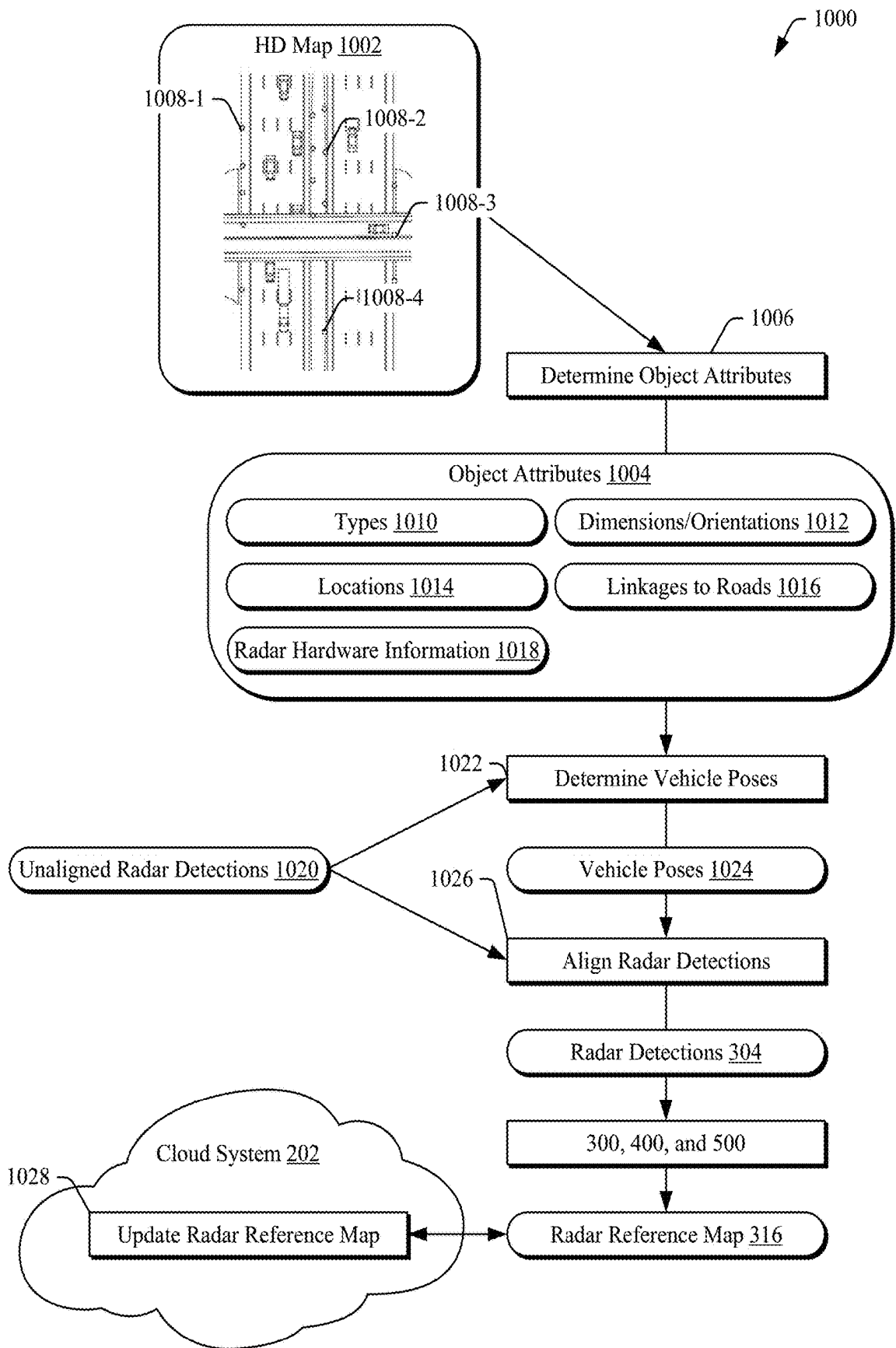

Fig. 10

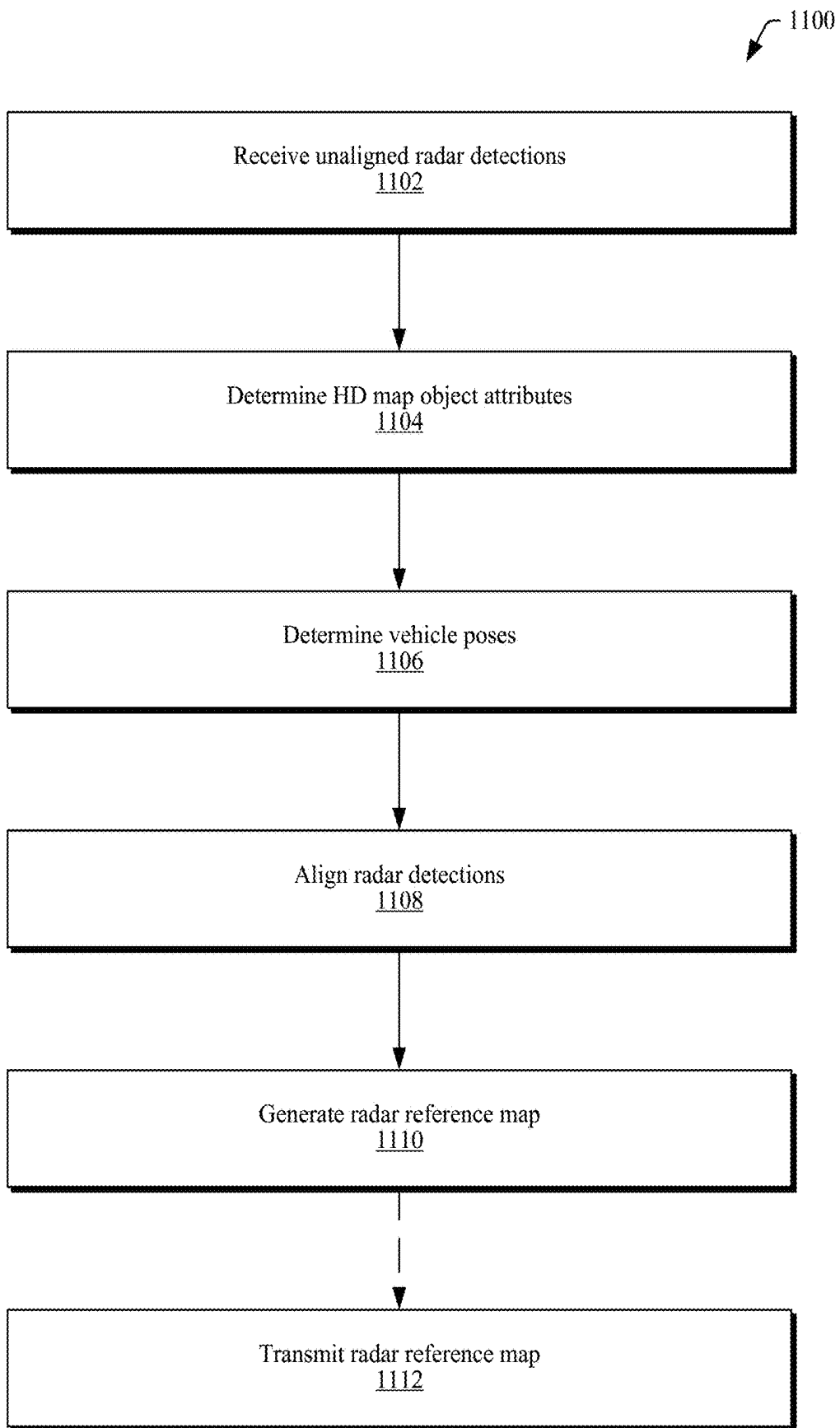

Fig. 11

1200

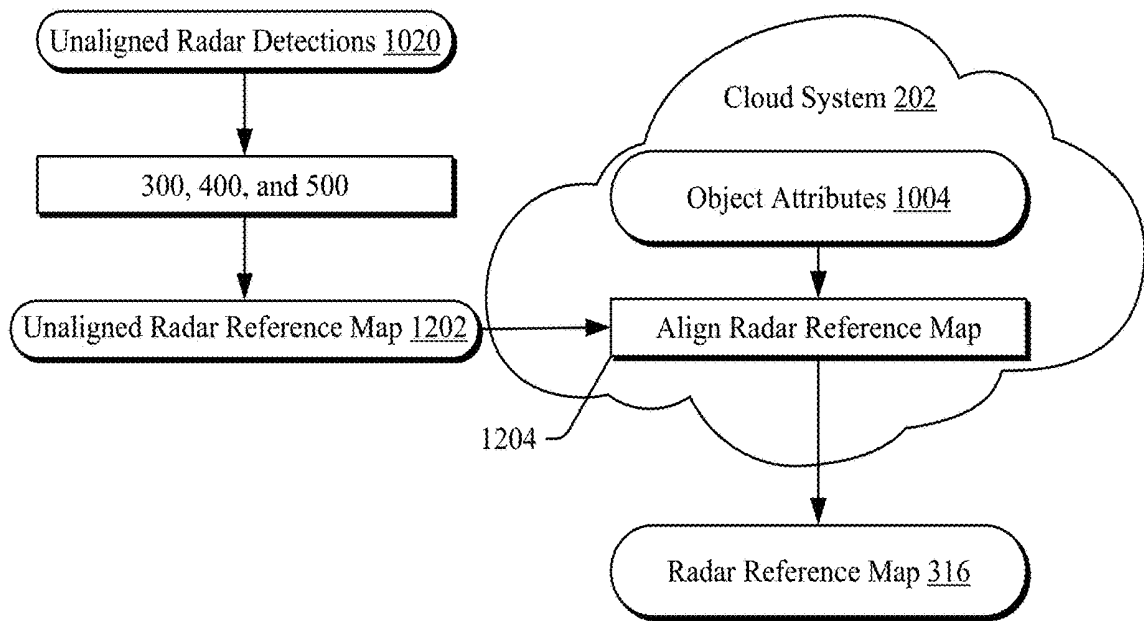

Fig. 12

1300

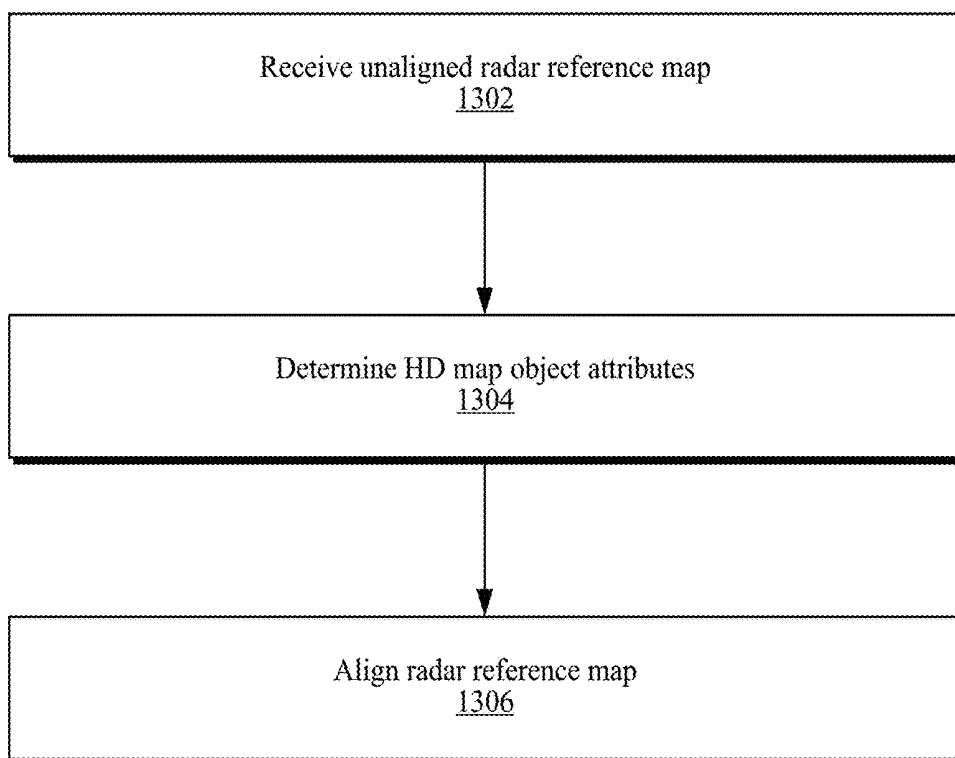

Fig. 13

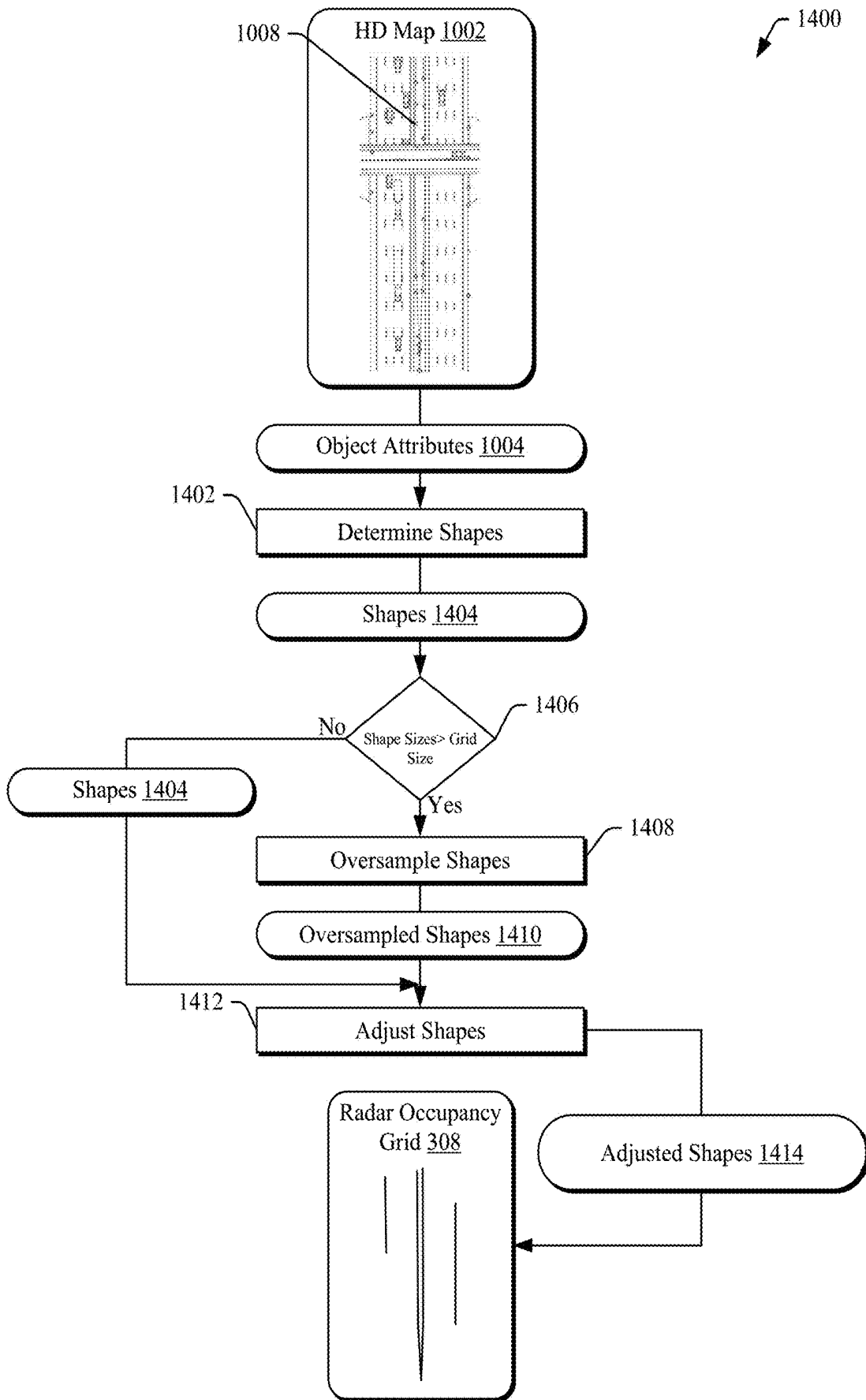

Fig. 14

1500

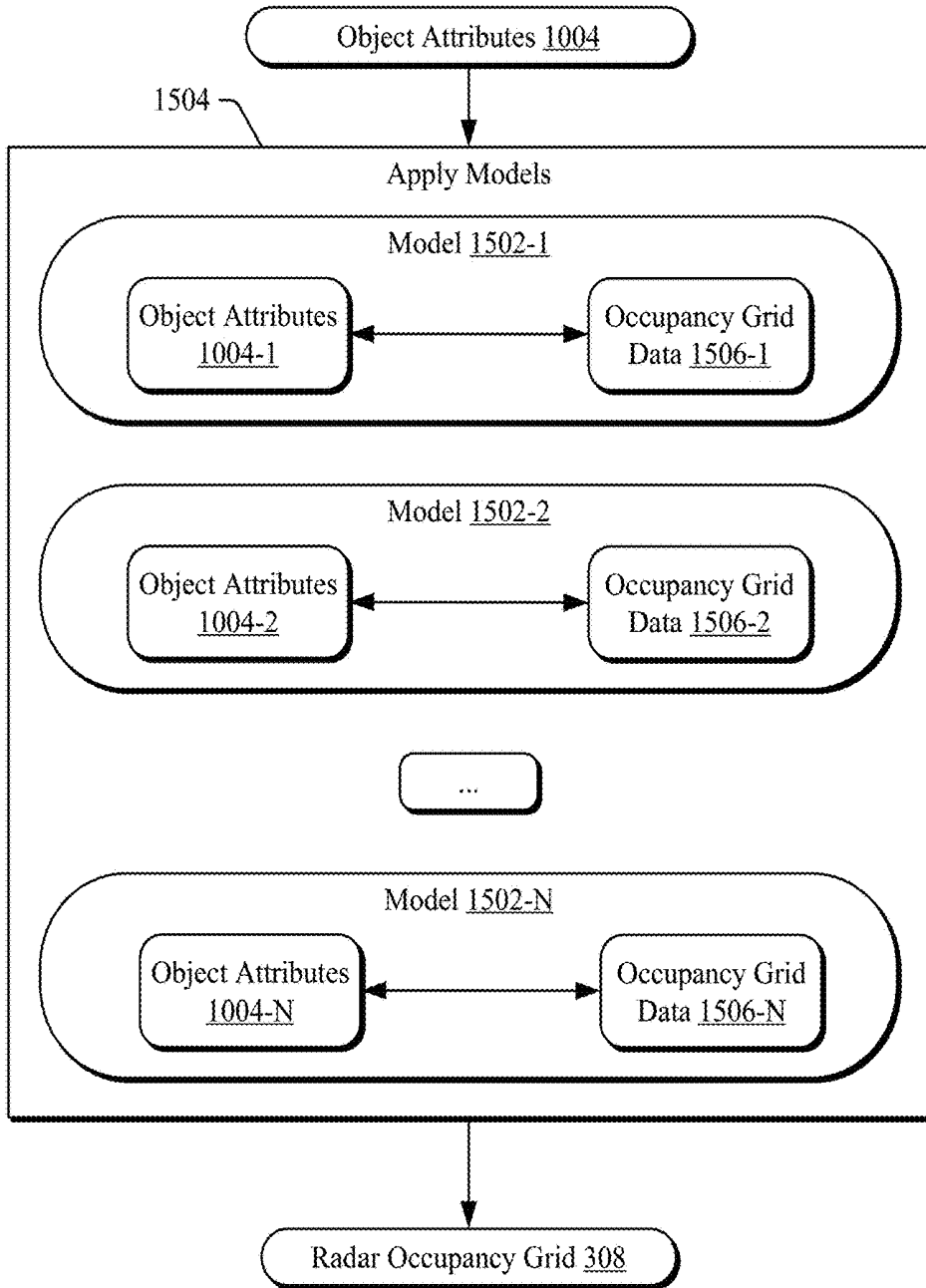

Fig. 15

1600 ↙

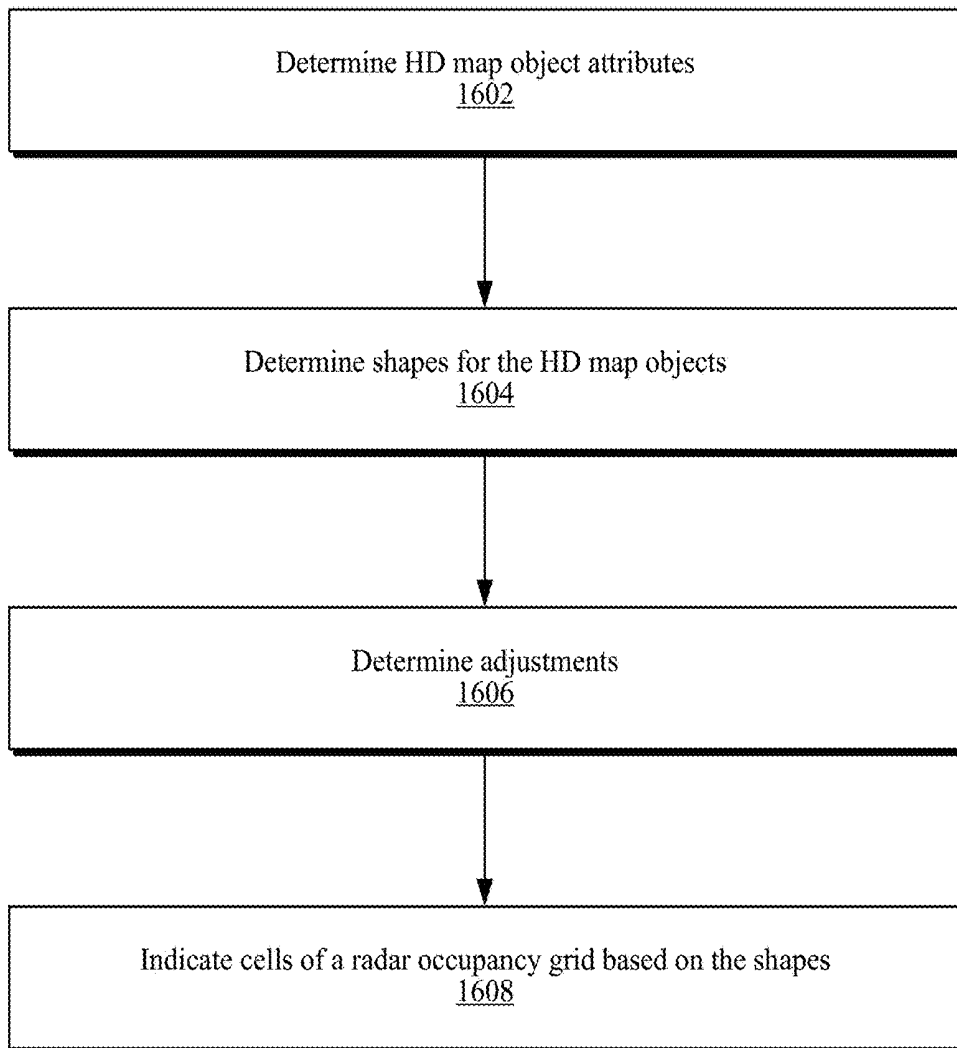

Fig. 16

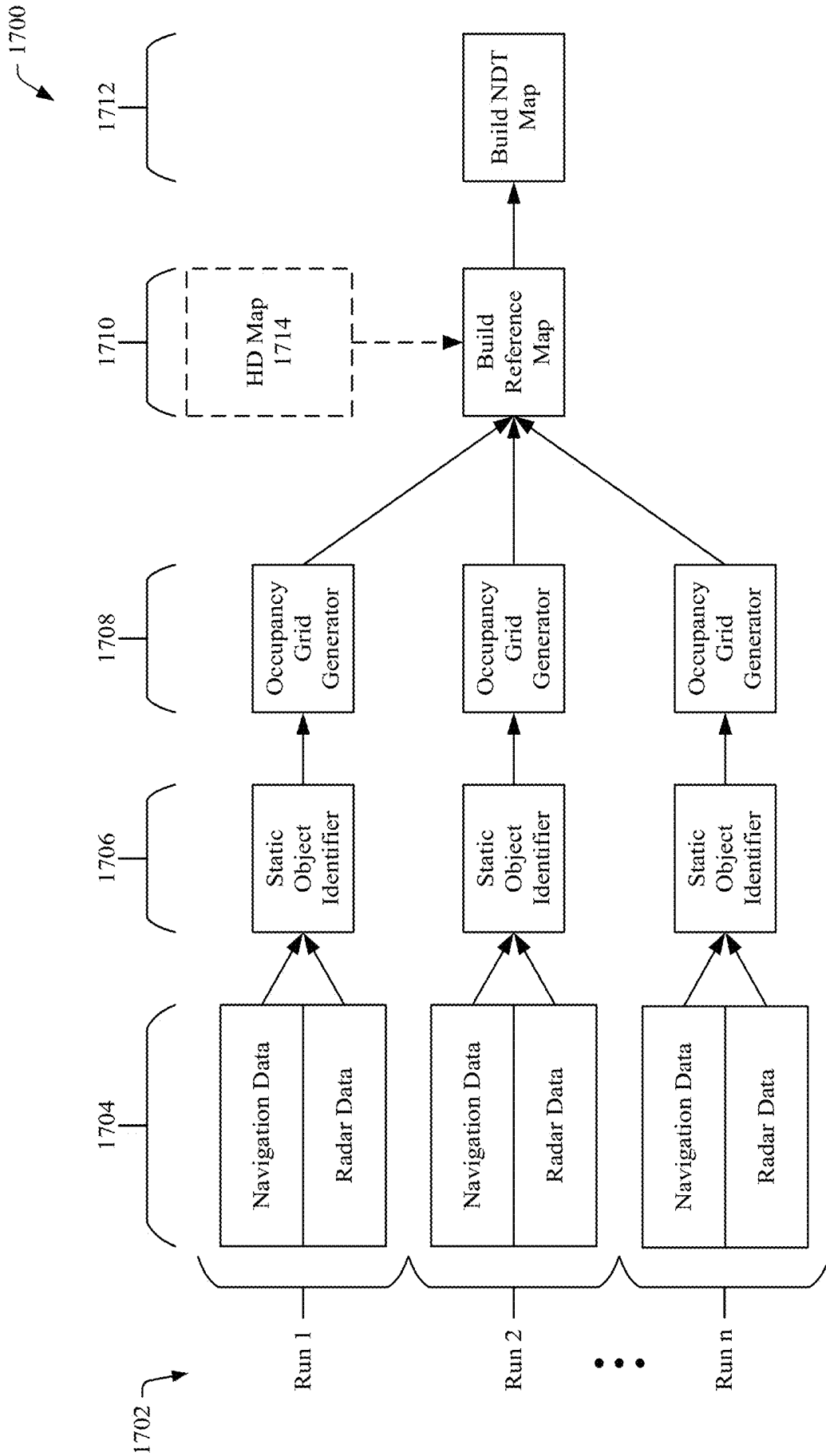

Fig. 17

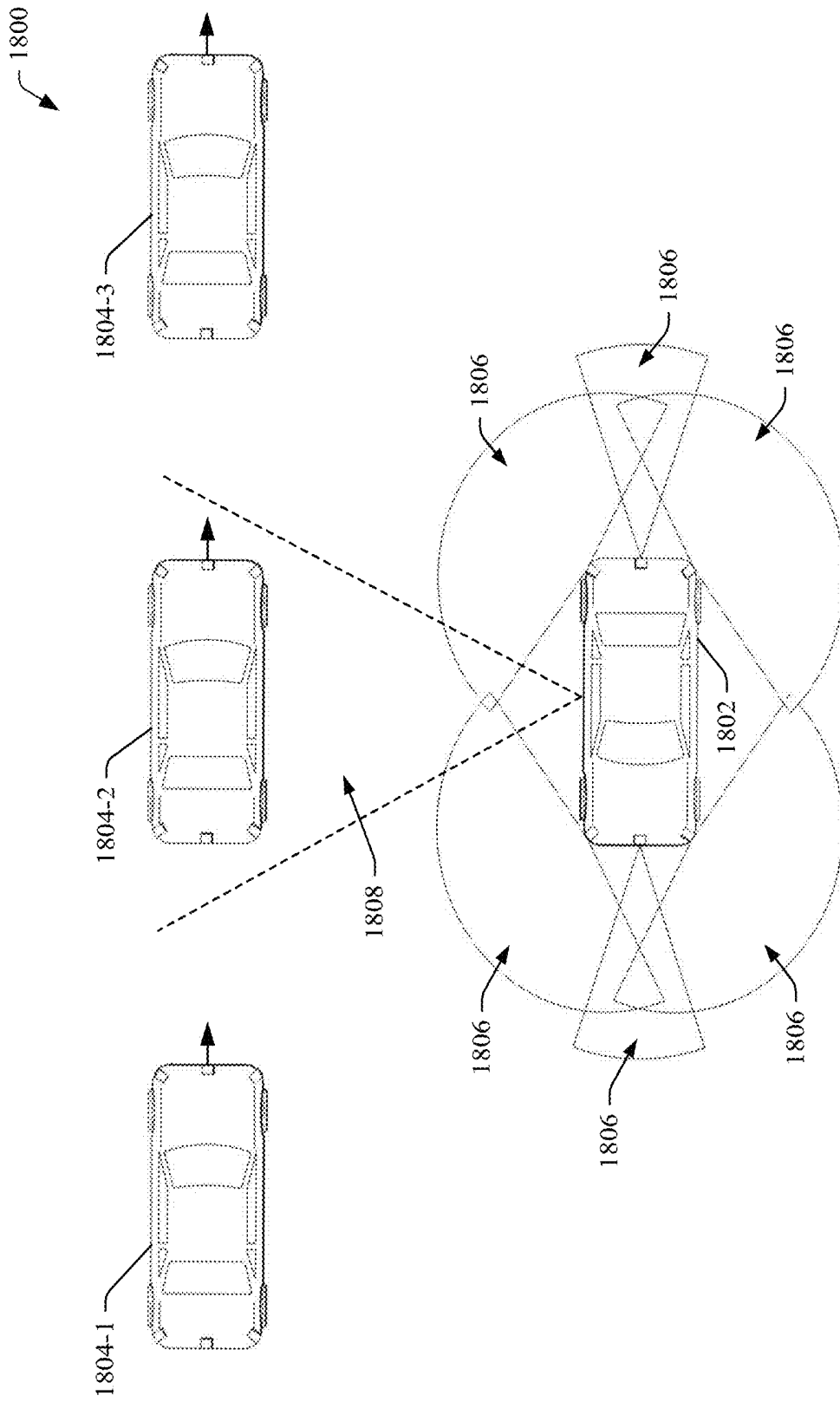

Fig. 18

1900 ↙

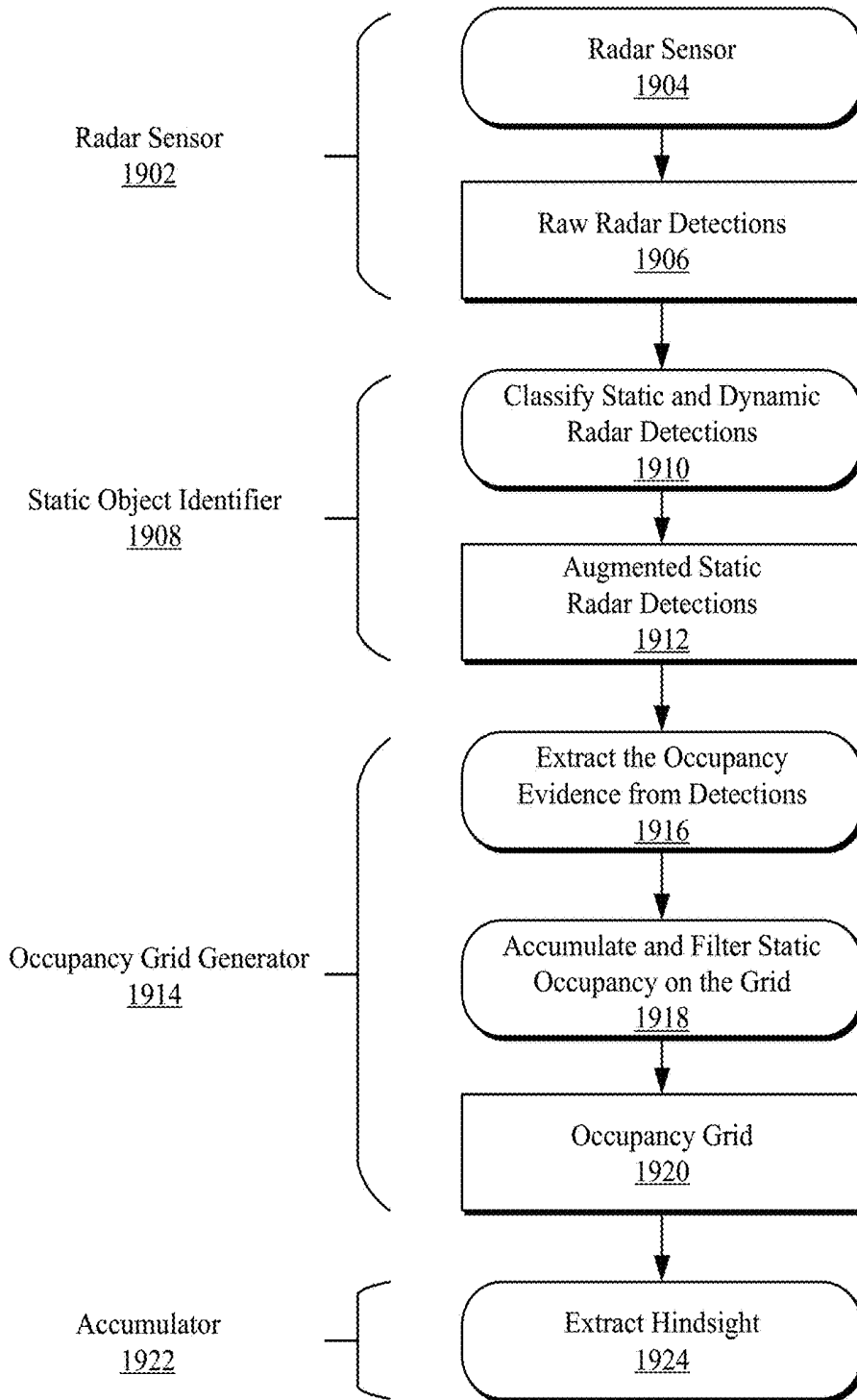

Fig. 19

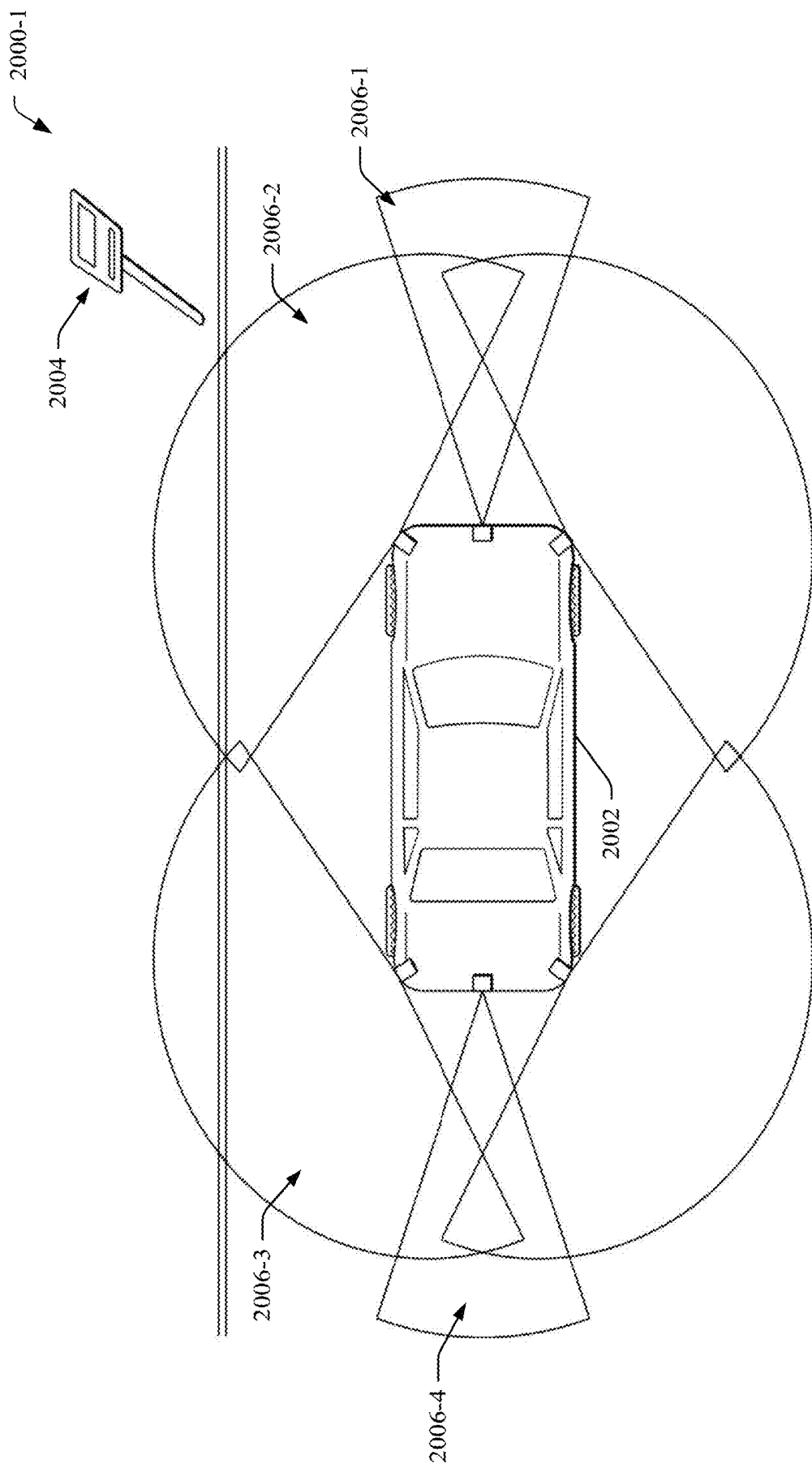

Fig. 20-1

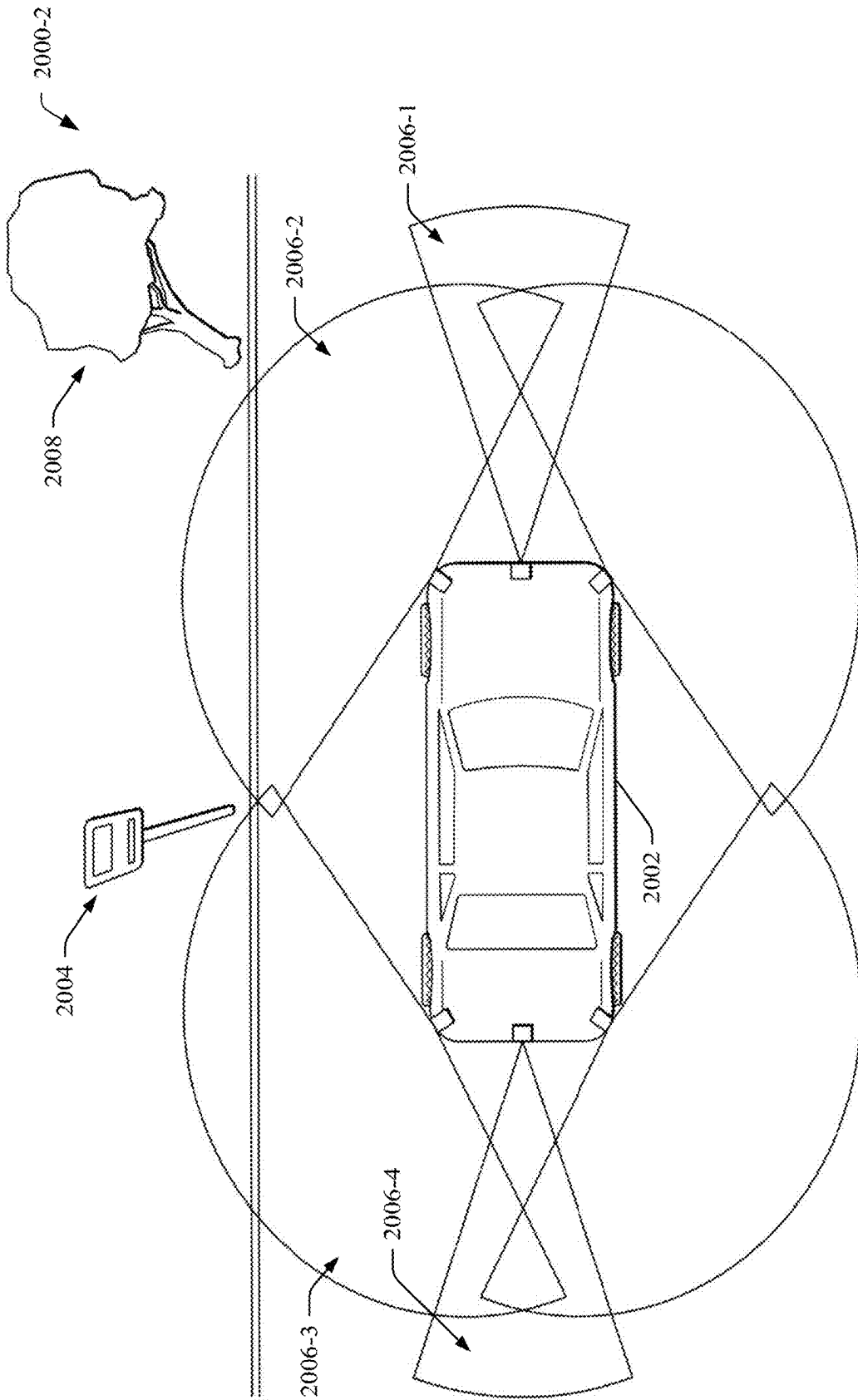

Fig. 20-2

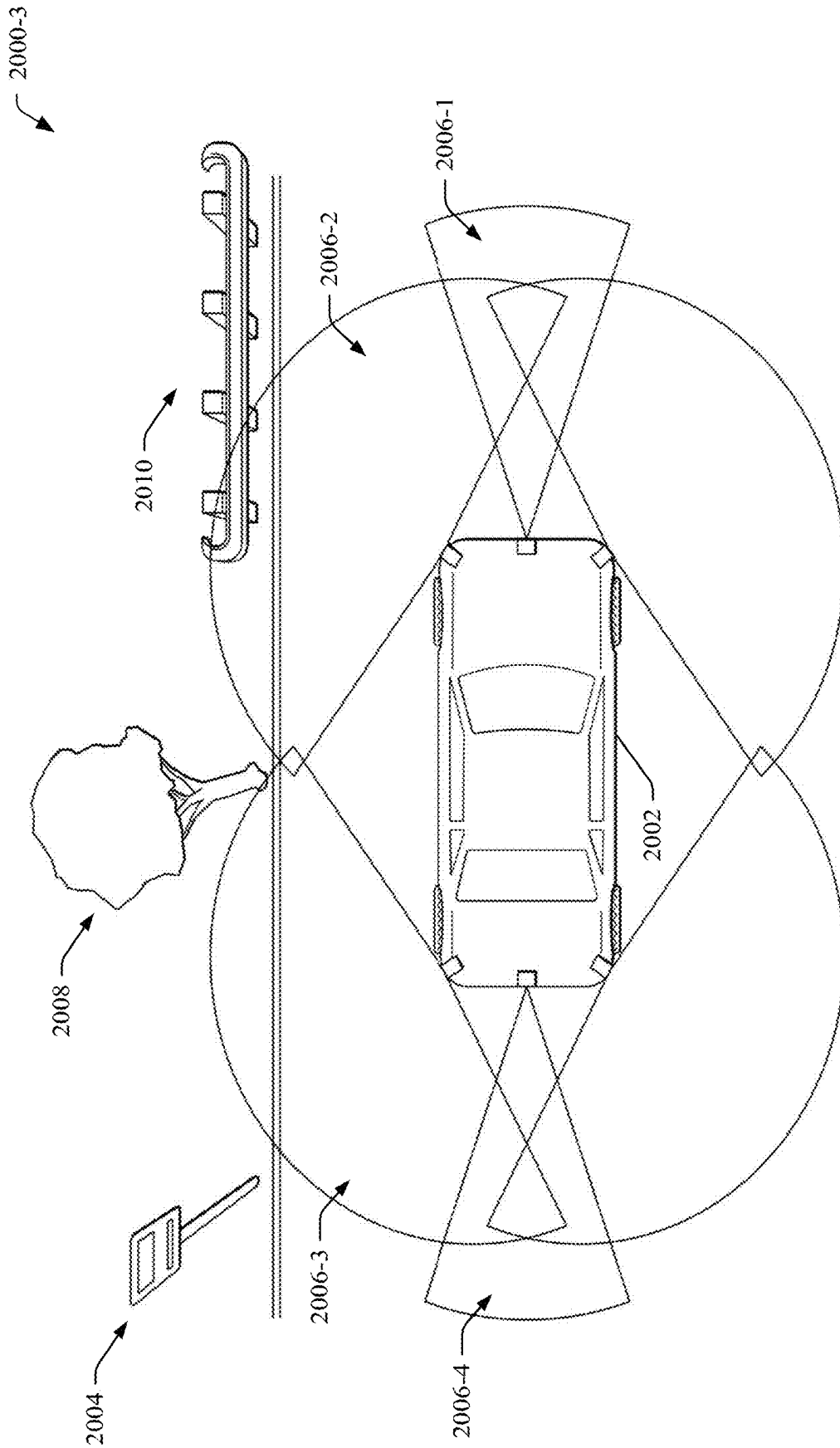

Fig. 20-3

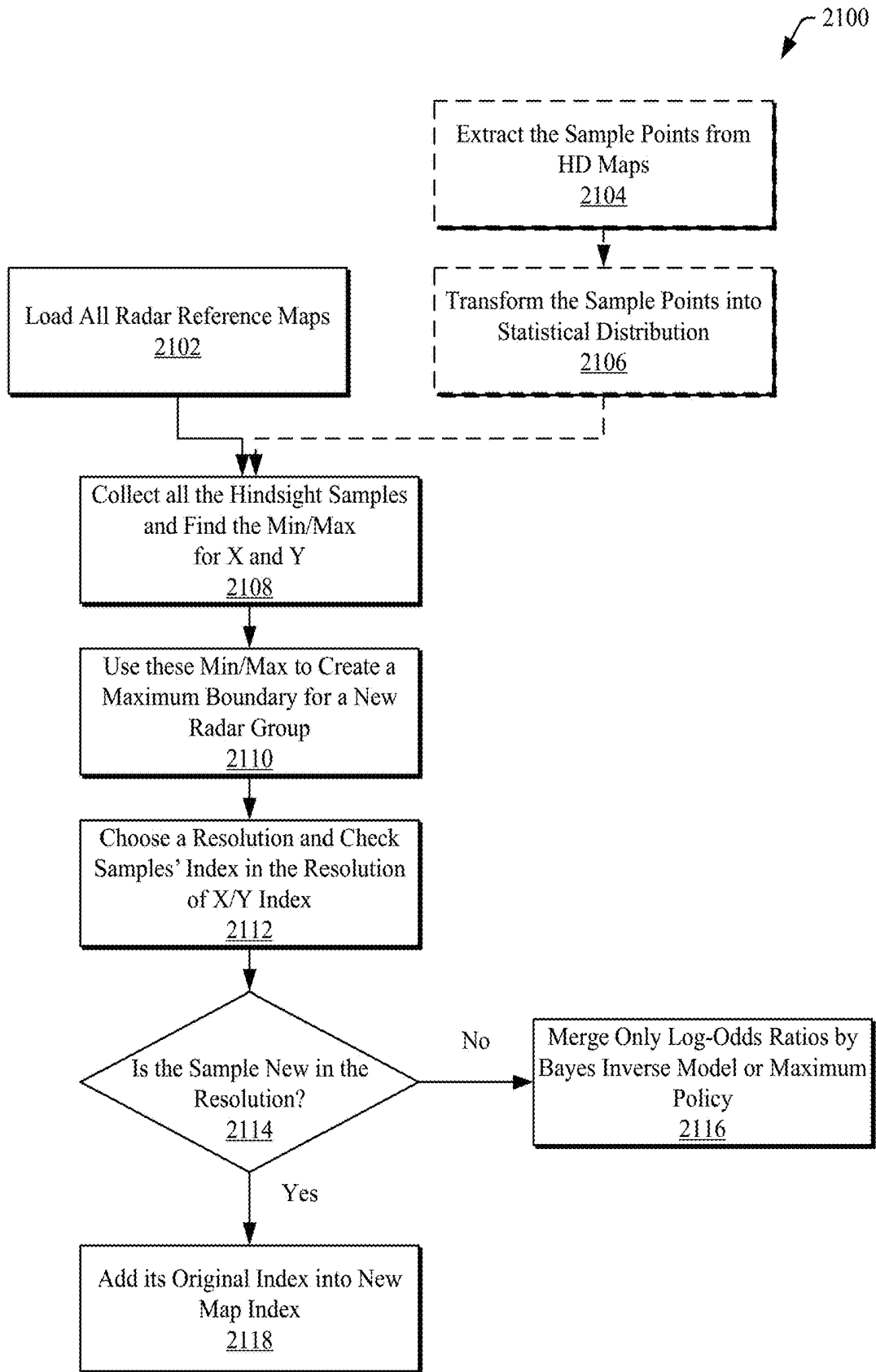

Fig. 21

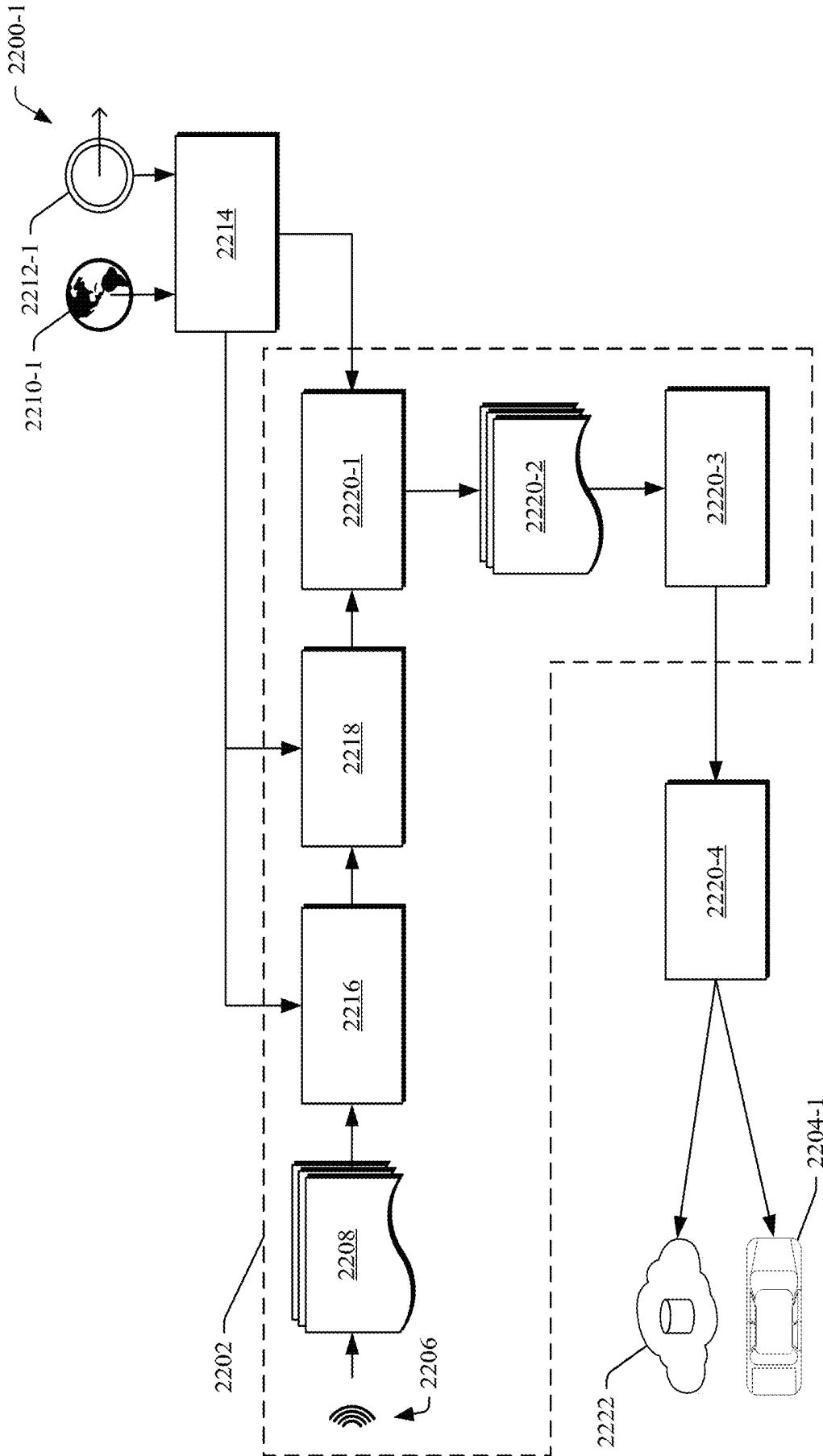

Fig. 22-1

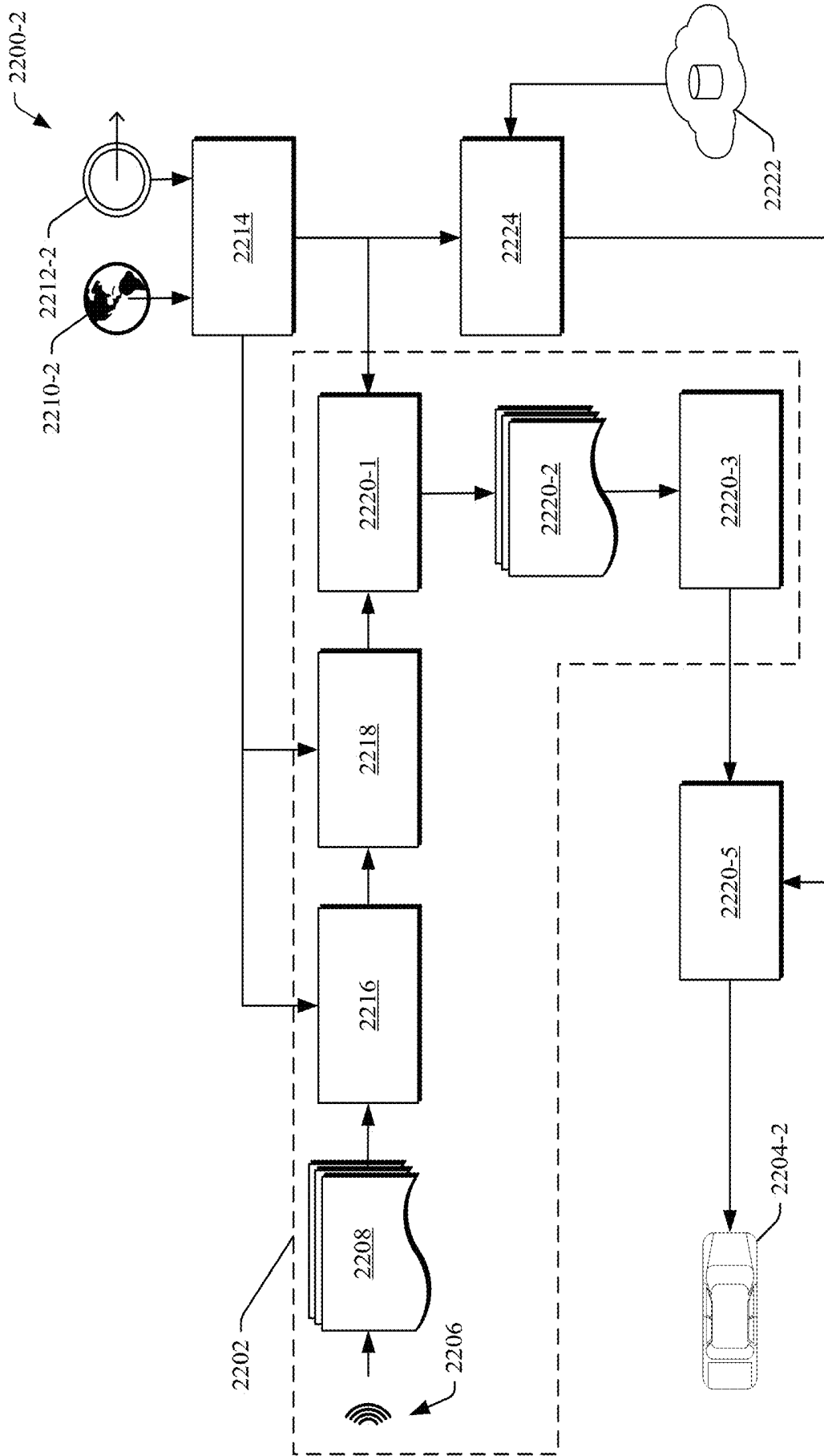

Fig. 22-2

2300

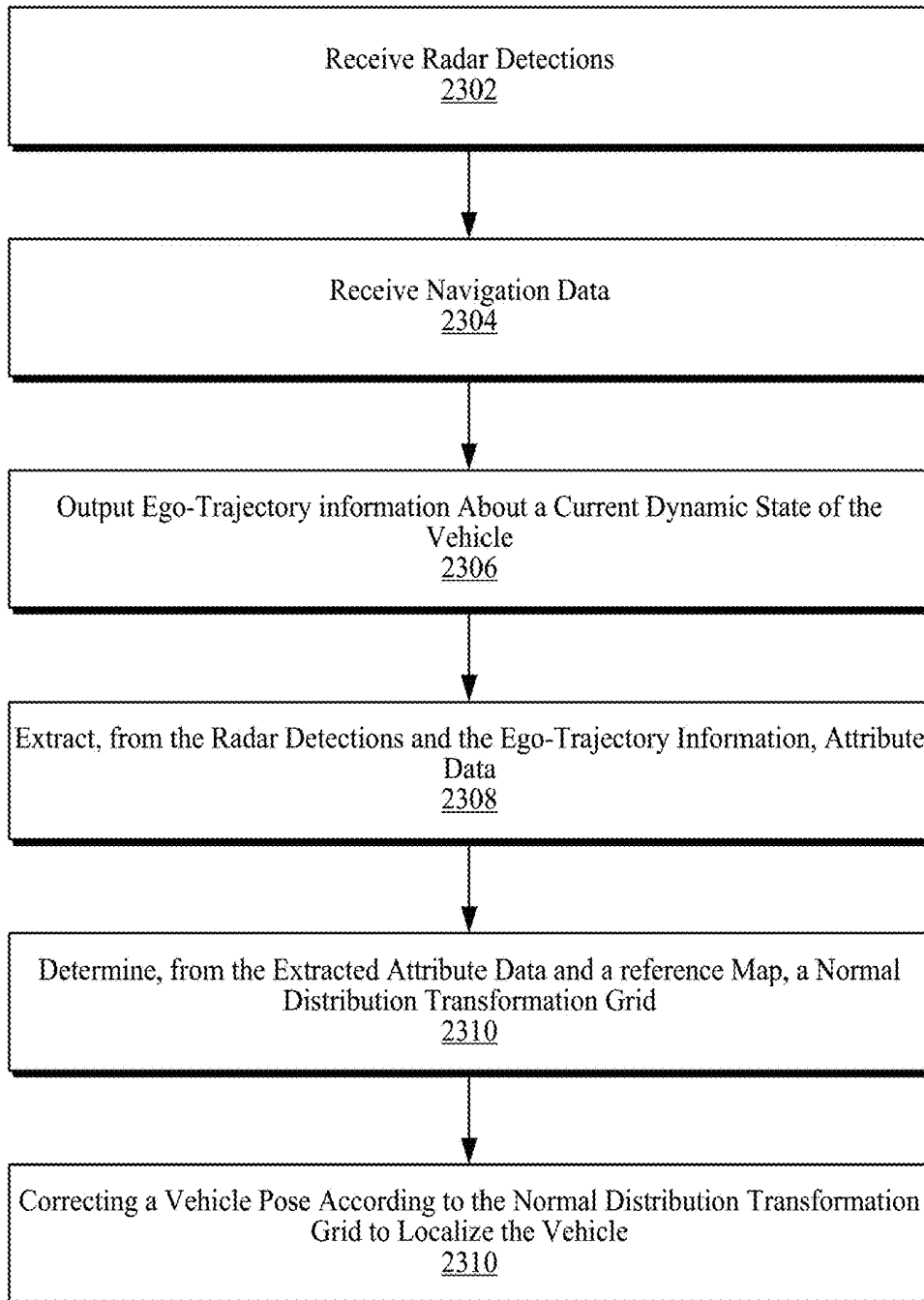

Fig. 23

RADAR REFERENCE MAP GENERATION

CROSS-REFERENCE TO RELATED APPLICATIONS

[0001] This application claims the benefit under 35 U.S.C. 119(e) of U.S. Provisional Application No. 63/146,483, filed Feb. 5, 2021, and U.S. Provisional Application No. 63/127,049, filed Dec. 17, 2020, the disclosures of which are incorporated by reference in their entireties herein.

BACKGROUND

[0002] Radar localization is a technique of using radar reflections to localize a vehicle to a reference map (e.g., determining a location of the vehicle on the map). Radar localization may be used to support autonomous vehicle operations (e.g., navigation, path planning, lane determination and centering, and curve execution without lane markers). In order to accurately position the vehicle relative to its environment, radar localization includes obtaining reflections from stationary localization objects (e.g., road-adjacent objects or spatial statistical patterns) with known locations on the map (e.g., locations in a Universal Transverse Mercator or UTM frame). When an availability of such localization objects is not sufficient (e.g., a poor quality or incomplete radar reference map is used), a driver takeover is often initiated, which may override semi-autonomous or fully autonomous controls. Increased driver takeovers may be less safe, and their frequency can decrease driver satisfaction compared to when a vehicle operates under autonomous control. As such, complete and accurate maps that are easy to generate, update, and use can greatly benefit driver assist or autonomous driving capabilities.

SUMMARY

[0003] Aspects described below include methods for radar reference map generation. The methods include receiving a high-definition (HD) map and determining one or more HD map objects within the HD map. The methods also include determining attributes of the respective HD map objects and, for each HD map object, indicating one or more occupancy cells of a radar occupancy grid as occupied space based on the attributes of the respective HD map object.

[0004] Aspects described below also include systems for radar reference map generation. The systems include at least one processor and at least one computer-readable storage medium comprising instructions that, when executed by the processor, cause the systems to receive a high-definition (HD) map and determine one or more HD map objects within the HD map. The instructions also cause the systems to determine attributes of the respective HD map objects and, for each HD map object, indicate occupancy cells of a radar occupancy grid as occupied space based on the attributes of the respective HD map object.

BRIEF DESCRIPTION OF THE DRAWINGS

[0005] Systems and techniques enabling radar reference map generation are described with reference to the following drawings. The same numbers are used throughout the drawings to reference like features and components:

[0006] FIG. 1 is an example illustration of an environment in which radar reference map generation may be implemented, in accordance with techniques of this disclosure;

[0007] FIG. 2-1 is an example illustration of systems that may be used to implement radar reference map generation and vehicle localization based on radar detections, in accordance with techniques of this disclosure;

[0008] FIG. 2-2 is an example illustration of a radar-localization module that may be used to implement vehicle localization based on radar detections;

[0009] FIG. 2-3 is another example illustration of a radar-localization module that may be used to implement vehicle localization based on radar detections;

[0010] FIG. 3 is an example illustration of generating a radar reference map, in accordance with techniques of this disclosure;

[0011] FIG. 4 is an example illustration of determining a radar occupancy grid, in accordance with techniques of this disclosure;

[0012] FIG. 5 is an example illustration of generating a radar reference map from radar attributes, in accordance with techniques of this disclosure;

[0013] FIG. 6 is an example illustration of a process of generating a radar reference map, in accordance with techniques of this disclosure;

[0014] FIG. 7 is an example illustration of generating a radar occupancy grid based on multiple vehicle-runs with low-accuracy location data, in accordance with techniques of this disclosure;

[0015] FIG. 8 is another example illustration of generating a radar occupancy grid based on multiple vehicle-runs with low-accuracy location data, in accordance with techniques of this disclosure;

[0016] FIG. 9 is an example illustration of a process of generating a radar occupancy grid based on multiple vehicle-runs with low-accuracy location data, in accordance with techniques of this disclosure;

[0017] FIG. 10 is an example illustration of generating a radar reference map using low-accuracy location data and a high-definition (HD) map, in accordance with techniques of this disclosure;

[0018] FIG. 11 is an example illustration of a process of generating a radar reference map using low-accuracy location data and an HD map, in accordance with techniques of this disclosure;

[0019] FIG. 12 is another example illustration of generating a radar reference map using low-accuracy location data and an HD map, in accordance with techniques of this disclosure;

[0020] FIG. 13 is another example illustration of a process of generating a radar reference map using low-accuracy location data and an HD map, in accordance with techniques of this disclosure;

[0021] FIG. 14 is an example illustration of determining a radar occupancy grid using an HD map, in accordance with techniques of this disclosure;

[0022] FIG. 15 is another example illustration of determining a radar occupancy grid using an HD map, in accordance with techniques of this disclosure;

[0023] FIG. 16 is an example illustration of a process of determining a radar occupancy grid using an HD map, in accordance with techniques of this disclosure;

[0024] FIG. 17 illustrates a flow chart as an example process for updating, through multiple iterations, a radar reference map used for vehicle localization based on radar detections, in accordance with techniques of this disclosure;

[0025] FIG. 18 illustrates an example implementation 1800 of a system configured to update, through multiple iterations, a radar reference map used for vehicle localization based on radar detections, in accordance with techniques of this disclosure;

[0026] FIG. 19 illustrates a pipeline for updating, through multiple iterations, a radar reference map used for vehicle localization based on radar detections, in accordance with techniques of this disclosure;

[0027] FIGS. 20-1 to 20-3 illustrate an example implementation of hindsight used to update, through multiple iterations, a radar reference map used for vehicle localization based on radar detections, in accordance with techniques of this disclosure;

[0028] FIG. 21 illustrates an example process for determining a hindsight maximum boundary for radar coordinates when updating, through multiple iterations, a radar reference map used for vehicle localization based on radar detections, in accordance with techniques of this disclosure;

[0029] FIGS. 22-1 to 22-2 illustrate a flow chart of an example of a process for vehicle localization based on radar detections, in accordance with techniques of this disclosure; and

[0030] FIG. 23 illustrates a flow chart of an example process for vehicle localization based on radar detections.

DETAILED DESCRIPTION

[0031] Overview

[0032] Radar localization is a technique of using radar reflections to localize a vehicle relative to stationary objects (e.g., radar-localization objects). One application of radar localization is localizing a vehicle to a map, similar to geospatial positioning systems (e.g., GPS, GNSS, GLO-NASS). Just as those positioning systems require adequate signal reception, radar localization requires radar reflections from radar-localization objects with known locations (e.g., guardrails, signs, or statistical patterns). The locations of those objects are generally comprised by a radar-reference map.

[0033] Methods and systems are described that enable radar reference map generation. By utilizing the techniques described herein, robust and wide-spanning radar reference maps may be generated, often times without dedicated or expensive sensor modules. For example, a radar occupancy grid is received, and radar attributes are determined from occupancy probabilities within the radar occupancy grid. Radar reference map cells are formed, and the radar attributes are used to determine Gaussians for the radar reference map cells that contain a plurality of the radar attributes. A radar reference map is then generated that includes the Gaussians determined for the radar referenced map cells that contain the plurality of radar attributes. By doing so, the generated radar reference map is accurate while being spatially efficient. This improved localization capability may improve driving when used by a controller to operate the vehicle with greater safety and comfort. With improved localization, the vehicle does not hesitate and can maneuver in an environment with greater degrees of accuracy, which may put passengers at ease when the vehicle drives under automated or semi-automated control.

[0034] Example Environment

[0035] FIG. 1 is an example illustration 100 of an environment in which radar reference maps may be generated, updated, or used. In the example illustration 100, a system

102 is disposed in a vehicle 104 (e.g., a host vehicle or “ego-vehicle”) that is traveling along a roadway 106.

[0036] The system 102 utilizes a radar system (not shown) to transmit radar signals (not shown). The radar system receives radar reflections 108 of the radar signals from objects 110. In example illustration 100, the radar reflection 108-1 corresponds to object 110-1 (e.g., a sign), the radar reflection 108-2 corresponds to object 110-2 (e.g., a building), and the radar reflection 108-3 corresponds to object 110-3 (e.g., a guardrail).

[0037] The radar reflections 108 may be used to generate a radar reference map, as discussed in reference to FIGS. 3-13. The radar reflections 108 may also be used to update an existing radar reference map, as discussed in reference to FIGS. 17-21. The radar reflections 108 may further be used in conjunction with an existing radar reference map to radar-localize the vehicle 104, as discussed in reference to FIGS. 22 and 23.

[0038] Example Systems

[0039] FIG. 2-1 is an example illustration 200-1 of systems that may be used to generate, update, or use radar reference maps. The example illustration 200-1 comprises the system 102 of the vehicle 104 and a cloud system 202. Although the vehicle 104 is illustrated as a car, the vehicle 104 may comprise any vehicle (e.g., a truck, a bus, a boat, a plane, etc.) without departing from the scope of this disclosure. The system 102 and the cloud system 202 may be connected via communication link 204. One or both of the system 102 and the cloud system 202 may be used to perform the techniques described herein.

[0040] As shown underneath the respective systems, the systems include at least one processor 206 each (e.g., processor 206-1 and processor 206-2), at least one computer-readable storage medium 208 each (e.g., computer-readable storage medium 208-1 and 208-2), radar-localization modules 210 (e.g., radar-localization module 210-1 and 210-2), and communication systems 212 (e.g., communication system 212-1 and 212-2). The communication systems 212 facilitate the communication link 204.

[0041] The system 102 additionally contains a navigation system 214 and a radar system 216. The navigation system 214 may include a geospatial positioning system (e.g., a GPS, GNSS, or GLONASS sensor), an inertial measurement system (e.g., a gyroscope or accelerometer), or other sensors (e.g., a magnetometer, software positioning engine, wheel tick sensor, lidar odometer, vision odometer, radar odometer, or other sensor odometer). The navigation system 214 may provide high-accuracy location data (e.g., to within a meter) or low-accuracy location data (e.g., to within a couple of meters). The radar system 216 is indicative of a radar hardware used to transmit and receive radar signals (e.g., radar reflections 108). In some implementations, the radar system 216 provides static detections to the radar-localization modules 210 (e.g., filtering may be performed within the radar system 216).

[0042] The processors 206 (e.g., application processors, microprocessors, digital-signal processors (DSP), or controllers) execute instructions 218 (e.g., instructions 218-1 and 218-2) stored within the computer-readable storage media 208 (e.g., non-transitory storage devices such as hard drives, SSD, flash memories, read-only memories (ROM), EPROM, or EEPROM) to cause the system 102 and cloud system 202 to perform the techniques described herein. The

instructions **218** may be part of operating systems and/or one or more applications of the system **102** and cloud system **202**.

[0043] The instructions **218** cause the system **102** and the cloud system **202** to act upon (e.g., create, receive, modify, delete, transmit, or display) data **220** (e.g., **220-1** and **220-2**). The data **220** may comprise application data, module data, sensor data, or I/O data. Although shown as being within the computer-readable storage media **208**, portions of the data **220** may be within random-access memories (RAM) or caches of the system **102** and the cloud system **202** (not shown). Furthermore, the instructions **218** and/or the data **220** may be remote to the system **102** and the cloud system **202**.

[0044] The radar-localization modules **210** (or portions thereof) may be comprised by the computer-readable storage media **208** or be stand-alone components (e.g., executed in dedicated hardware in communication with the processors **206** and computer-readable storage media **208**). For example, the instructions **218** may cause the processors **206** to implement or otherwise cause the system **102** or the cloud system **202** to implement the techniques described herein.

[0045] FIG. 2-2 is an example illustration **200-2** of the radar-localization module **210** that may be used to implement vehicle localization based on radar detections. In the example illustration **200-2**, the radar-localization module **210** is configured to be in a reference mode. The reference mode is used when the radar-localization module **210** is being used to build a radar reference map. The radar-localization module **210** includes two sub-modules, a vehicle state estimator **222**, a scan-matcher **224**, and two optional sub-modules, a static object identifier **226**, and an occupancy grid generator **228**. One or both of the static object identifier **226** and the occupancy grid generator **228** may or may not be present.

[0046] The vehicle state estimator **222** receives navigation data **230** from navigation systems (e.g., the navigation system **214** from FIG. 2-1). Generally, in the reference mode, the navigation data **230** may be sourced from a high-quality navigation system that provides a higher degree of accuracy than commercial or consumer-grade navigation systems (e.g., navigation systems used for mass production). From the navigation data **230**, the vehicle state estimator **222** determines ego-trajectory information about the current dynamic state (e.g., speed, yaw rate) of the vehicle **104** and may provide the state estimates and other navigation data **230** (e.g., latitude and longitude of the vehicle **104**) to any of the other sub-modules that are present in the radar-localization module **210**. Ego-trajectory information includes information, originating from systems of a vehicle, that may be used to project the direction and velocity of the vehicle.

[0047] The static object identifier **226** receives radar detections **232** from one or more radar sensors positions around the vehicle **104**. If the static object identifier **226** is not being utilized, then the radar detections **232** may be received by the occupancy grid generator **228**, the scan-matcher **224**, or another sub-module designed to accept the radar detections **232** and distribute the radar data to other modules and sub-modules of the vehicle system. The static object identifier **226** determines whether a radar detection **232** is a static detection based on the ego-trajectory information from the vehicle state estimator **222** and outputs any

identified static detections to either the occupancy grid generator **228**, if it is being utilized, or the scan-matcher **224**.

[0048] The occupancy grid generator **228** may receive, as inputs, either the radar detections **232**, if the static object identifier **226** is not being utilized by the radar-localization module **210**, or the static radar detections output by the static object identifier **226**, as well as, the ego-trajectory information and the navigation data **230** output from the vehicle state estimator **222**. The occupancy grid generator **228** uses the inputs to determine a statistical probability (e.g., occupancy grid) of the occupancy at any given location in the environment of the vehicle **104**, as discussed in other sections of this document.

[0049] The scan-matcher **224** may receive, as input, the ego-trajectory information and attribute data. Attribute data may be either the radar detections **232**, the static radar detections from the static object identifier **226**, or the occupancy grid that is output by the occupancy grid generator **228**, depending on which optional sub-modules are being utilized. As described in other sections of this document, the scan-matcher **224** finds an optimal normal distribution transformation (NDT) between the attribute data and the high-quality navigation data **230** and outputs an NDT radar reference map **234**.

[0050] FIG. 2-3 is another example illustration **200-3** of a radar-localization module that may be used to implement vehicle localization based on radar detections. In the example illustration **200-3**, the radar-localization module **210** is configured to be in a real-time localization mode. The primary differences between the real-time localization mode and the reference mode of the radar-localization module **210** include the navigation data **230** originating from a lower-quality navigation system and an extra input to the scan-matcher module **224**. The output of the radar-localization module **210** in real-time localization mode is an updated vehicle pose **236** of the vehicle **104**.

[0051] In real-time localization mode, the scan-matcher **224** receives the NDT radar reference map **234** as input, in addition to the attribute data and the ego-trajectory information. The inputs are used by the scan-matcher to determine an NDT grid. The NDT grid is compared to the NDT radar reference map to determine the updated vehicle pose **236**.

[0052] In one non-limiting example, the radar-localization module **210** may be used in the reference mode in the vehicle **104**, equipped with a high-quality GNSS system, that is specially configured to create or assist in the creation of NDT radar reference maps. The real-time localization mode may be considered a normal operating mode of the radar-localization module **210**; that is, vehicles not specially configured to create the NDT radar reference maps may normally operate with the radar-localization module **210** in the real-time localization mode.

[0053] Building a Radar Reference Map

[0054] FIG. 3 is an example illustration **300** of generating a radar reference map from radar detections. Example illustration **300** may be performed by the system **102** and/or the cloud system **202**. At **302**, radar detections **304** are received. The radar detections **304** comprise stationary radar detections (e.g., detections of stationary objects from radar system **216**) with corresponding global coordinates for respective times/locations (e.g., from navigation system **214**). The detections may be of objects such as signs, poles, barriers, landmarks, buildings, overpasses, curbs, or road-adjacent

objects such as fences, trees, flora, or foliage, or of spatial statistical patterns. The global coordinates may comprise high-accuracy location data (e.g., when the navigation system 214 is a high-accuracy navigation system). The radar detections 304 may comprise point clouds, have corresponding uncertainties, and/or include various radar data or sensor measurements.

[0055] At 306, a radar occupancy grid 308 is determined from the radar detections 302. The radar occupancy grid 308 is a grid-based representation of an environment. For example, the radar occupancy grid 308 may be a Bayesian, Dempster-Shafer, or other type of occupancy grid. Each cell of the radar occupancy grid 308 represents an independent portion of space, and each cell value of the radar occupancy grid 308 represents a probability (e.g., 0-100%) that the corresponding portion of space is occupied. A probability of around 0% for a cell may indicate that the corresponding portion of space is free, while a probability closer to 100% may indicate that the corresponding portion of space is occupied, and therefore, not free space. Techniques of determining the radar occupancy grid 308 are discussed further in regard to FIGS. 4, 7-9, and 14-17.

[0056] At 310, radar attributes 312 (e.g., attributes or attribute data) are determined from the radar occupancy grid 308. The radar attributes 312 may be center coordinates of respective groups of cells of the radar occupancy grid 308 with probabilities greater than a threshold. In some implementations, the radar attributes 312 may be based on other aspects such as radar cross sections (RCS), amplitudes of the radar detections 304, information from other sensors, or machine learning, separately or in combination with the probabilities. Regardless of how they are determined, the radar attributes 312 comprise clusters, contours, or bounding boxes of the cells of the radar occupancy grid 308. The radar attributes 312 may have weights based on one or more of probabilities, classifications, or cross-section values of the respective radar attributes 312. The radar attributes 312 may be determined using binarization, a clustering algorithm, or machine learning on the radar occupancy grid 308. The determination of the radar attributes 312 generally groups cells of the radar occupancy grid 308 while removing noise.

[0057] At 314, a radar reference map 316 is generated from the radar attributes 312. The radar reference map 316 may be a statistical reference map (e.g., a Gaussian representation). The radar reference map 316 is a collection of Gaussians 318 corresponding to occupied areas. The Gaussians 318 (or the cells of the radar reference map 316) have associated location information (e.g., low or high-quality location information depending on how the radar reference map 316 is generated). Each cell of the radar reference map 316 can have a single Gaussian 318 or be blank. Although not required, the radar reference map 316 has cells that are larger than the cells of the radar occupancy grid 308. The radar reference map 316 can be a stand-alone map or a layer in another map (e.g., a layer in a high-definition (HD) map).

[0058] The radar reference map 316 may contain metadata associated with the respective Gaussians 318. For example, the metadata may contain information about shapes or dimensions of clusters of Gaussians 318. The metadata may also include object associations, e.g., certain Gaussians 318 belong to a sign or guardrail. The location data may also be contained within the metadata. Techniques of generating the radar reference map 316 are discussed further in regard to FIGS. 5, 6, and 10-13.

[0059] FIG. 4 is an example illustration 400 of determining the radar occupancy grid 308 from the radar detections 304. Example illustration 400 is generally performed by the system 102, although portions or all of example illustration 400 may be performed by the cloud system 202. Example illustration 400 assumes that the location data associated with the radar detections 304 is high-accuracy location data (e.g., the navigation system 214 contains a high-accuracy GNSS).

[0060] At 402, one set (e.g., time) of the radar detections 304 is received (e.g., a radar detection 304 corresponding to a zero-point), and radar occupancy evidences 404 are determined from the one set of radar detections 304. The radar occupancy evidences 404 correspond to respective cells of the radar occupancy grid 308 and are indicative of occupied spaces within the radar occupancy grid 308. The radar occupancy evidences 404 are based on radar reflections 108 corresponding to the one set of radar detections 304 and associated range and azimuth uncertainties.

[0061] At 406, radar occupancy probabilities 408 are determined from the radar occupancy evidences 404. For example, the radar occupancy probabilities 408 may be given by Equation 1:

$$p=0.5+0.5 \cdot e \quad [1]$$

[0062] where p is a radar occupancy probability 408 and e is an occupancy evidence 404.

[0063] Steps 402 and 406 may be repeated for other sets of radar detections 304 corresponding to later times/locations. For each of the later times/locations, the radar occupancy probabilities 408 are fused, at 410, with a decayed and shifted radar occupancy grid 412. The decayed and shifted radar occupancy grid 412 represents a current radar occupancy grid 414 (e.g., the radar occupancy grid 308 at the current time/location) with decayed probabilities and cells that have been shifted due to a movement of the vehicle between the previous time/location and current ones. The fusing is used to update the radar occupancy grid 308 based on subsequent radar detections 304 corresponding to the later times/locations.

[0064] In order to generate the decayed and shifted radar occupancy grid 412, at 416, the current radar occupancy grid 414 (e.g., at the respective location) is decayed to form a decayed radar occupancy grid 418. The decay comprises forgetting, minimizing, or otherwise removing old evidence from the current radar occupancy grid 414. This ensures that only recently generated cells are used for the fusing. It should be noted that the radar occupancy grid 308 is not decayed; rather, the current radar occupancy grid 414, which is a snapshot of the radar occupancy grid 308, is decayed.

[0065] The decayed radar occupancy grid 418 is then shifted, at 420, to form the decayed and shifted radar occupancy grid 412. Each cell of the radar occupancy grid 308 (and the current radar occupancy grid 414) represents an area. As such, as the vehicle 104 moves, the grid must be shifted. To shift the grid, a vehicle position 422 at the time of the shift/decay is received. The decayed radar occupancy grid 418 is shifted by integer numbers of cells that correspond to the vehicle position 422. For example, the integer numbers may be based on a change between a vehicle position 422 that corresponds to the unshifted occupancy grid (e.g., the decayed radar occupancy grid 418 and the current radar occupancy grid 414) and the vehicle position 422.

[0066] As stated above, the decayed and shifted radar occupancy grid **412** is fused, at **410**, with the radar occupancy probabilities **408** of the current set of radar detections **304**. The fusion effectively accumulates radar occupancy probabilities **408** over time to enable the radar occupancy grid **308** to be more robust. Any fusion method may be used. For example, a Bayesian fusion method may be used according to Equation 2:

$$p_{new} = \frac{p_{old} \cdot p_{measured}}{(p_{old} \cdot p_{measured}) + (1 - p_{old}) \cdot (1 - p_{measured})} \quad [2]$$

[0067] where p_{new} is an occupancy probability for a respective cell (e.g., in the radar occupancy grid **308**), p_{old} is an existing radar occupancy probability for the respective cell (e.g., in the decayed and shifted radar occupancy grid **412**), and $p_{measured}$ is a radar occupancy probability **408** for the respective cell.

[0068] By using the example illustration **400**, radar occupancy probabilities **408** from multiple times/locations may be fused. In so doing, the radar occupancy grid **308** becomes accurate and robust for use in the example illustration **300**.

[0069] FIG. **5** is an example illustration **500** of determining the radar reference map **316** from the radar attributes **312**. At **502**, normal distribution transform (NDT) cells **504** are established. The NDT cells **504** are the cells of the radar reference map **316**. The NDT cells **504** are generally much larger (e.g., 15 times larger) than the cells of the radar occupancy grid **308**.

[0070] For each NDT cell **504** that has a plurality of radar attributes **312**, a Gaussian **318** (e.g., a multivariate distribution with a mean and covariance) is determined. In order to do so, at **506**, a mean and covariance **508** are determined for the respective NDT cell **504**. The mean and covariance **508** are based on radar attributes **312** identified within the respective NDT cell **504**. The mean for the respective NDT cell **504** may be determined based on Equation 3:

$$\mu_i = \sum_{j=1}^n p_j x_j \quad [3]$$

[0071] where p_j is the occupancy probability of the radar occupancy grid **308** at a given cell of the radar occupancy grid **308**, x_j is the given cell position, and n is a number of cells within the radar attributes **312** of the respective NDT cell **504**.

[0072] The covariance (e.g., 2x2 matrix) for the respective NDT cell **504** may be determined based on Equation 4:

$$\Sigma_i = \sum_{j=1}^n p_j (x_j - \mu_i)(x_j - \mu_i)^T \quad [4]$$

[0073] Advantageously, the mean and covariance **508** are based on occupancy probability. At **510**, the covariance for the respective NDT cell **504** may be manipulated such that the smallest eigenvalue of the covariance matrix is at least some multiple of the largest eigenvalue of the covariance matrix. The mean and covariance **508** (or a manipulated covariance if step **510** is performed) make up the Gaussian **318** for the respective NDT cell **504**. If there are one or fewer radar attributes **312** within the respective NDT cell **504**, the respective NDT cell **504** is indicated as unoccupied.

[0074] Steps **506** and **510** can then be performed for others of the NDT cells **504**. At **512**, the Gaussians **318** for the respective NDT cells **504** are combined to form the radar reference map **316**. Once combined, the NDT cells **504** of

the radar reference map **316** may a single Gaussian **318** or nothing (e.g., indicated as unoccupied).

[0075] Although steps **506** and **510** are discussed as being performed on a respective NDT cell **504** and then other NDT cells **504**, in some implementations, step **506** may be performed on the NDT cell **504** as a group prior to performing step **510** on the group. For example, the mean and covariance **508** may be determined for each NDT cell **504** of a group. Then, the covariances may be manipulated, as needed, for each NDT cell **504** of the group.

[0076] By using the techniques of example illustrations **300**, **400**, and **500**, an accurate and space efficient radar reference map may be generated. Using a space efficient map lowers computational requirements and enables faster localization to support driver assist and autonomous driving functionalities.

[0077] FIG. **6** is an example illustration **600** of a method of building the radar reference map **316**. The example illustration **600** may be implemented utilizing the previously described examples, such as the example illustrations **100**, **300**, **400**, and **500**. Operations **602** through **610** may be performed by one or more entities of the system **102** and/or the cloud system **202** (e.g., the radar-localization module **210**). The order in which the operations are shown and/or described is not intended to be construed as a limitation, and any number or combination of the operations can be combined in any order to implement the illustrated method or an alternate method.

[0078] At **602**, a radar occupancy grid is received. For example, the radar-localization module **210** may receive the radar occupancy grid **308**.

[0079] At **604**, radar attributes are determined from the radar occupancy grid. For example, the radar-localization module **210** may use thresholding on occupancy probabilities within the radar occupancy grid **308** to determine the radar attributes **312**. The radar attributes **312** may comprise center coordinates of respective groups of cells of the radar occupancy grid that have occupancy probabilities above a threshold, or within a threshold range.

[0080] At **606**, radar reference map cells are formed. For example, the radar-localization module **210** may create the NDT cells **504** of the radar reference map **316**.

[0081] At **608**, Gaussians are determined for radar reference map cells that contain a plurality of radar attributes. For example, the radar-localization module **210** may determine the mean and covariance **508** for each of the NDT cells **504** that contain a plurality of radar attributes **312**.

[0082] At **610**, a radar reference map is generated. The radar reference map comprises the radar reference map cells that include the Gaussians and radar reference map cells that are indicated as unoccupied. The radar reference map cells that are indicated as unoccupied correspond to radar reference map cells that do not contain a plurality of radar attributes. For example, the radar-localization module **210** may combine the NDT cells **504** with Gaussians **318** and NDT cells **504** that are indicated as unoccupied to form the radar reference map **316**.

[0083] FIG. **7** is an example illustration **700** of determining the radar occupancy probabilities **408** using multiple vehicle runs with low-accuracy location data. FIG. **8** is an example illustration **800** of a similar process. As such, the following description describes example illustrations **700** and **800** simultaneously. Example illustrations **700** and **800** are generally performed by the cloud system **202** based on

radar detections **304** received from the multiple vehicle runs, although one or more of the steps may be performed by the system **102** (e.g., the gathering of the radar detections **304** and transmitting the radar detections **304** to the cloud system **202** using the communication system **212**). The radar occupancy probabilities **408** may then be fused at **410** to create the radar occupancy grid **308**. The radar reference map **316** may then be generated from the radar occupancy grid **308**, similar to example illustrations **100** and **300**.

[0084] Gathering high-accuracy location data is often impractical or expensive for large areas. Example illustrations **700** and **800** determine the radar occupancy probabilities **408** using multiple runs with low-accuracy location data, such as that generated by most navigation systems (e.g., navigation system **214**) implemented within consumer and commercial vehicles. Because of the low-accuracy location data, multiple runs are needed to get occupancy probabilities **408** that are accurate. Conventional techniques, such as multiple run averaging, often lead to smeared and useless probability data.

[0085] Example illustrations **700** and **800** use a statistical map fusion of multiple runs **702** (e.g., run **702A** and run **702B**) to correct for the errors in the low-accuracy location data. Any number of runs **702** may be used (albeit more than one), and the runs **702** may be created using the same vehicle or multiple vehicles and at different times. The statistical map fusion may be an extended particle filter simultaneous localization and mapping (SLAM) algorithm.

[0086] At **704**, particles **706** are created at a given location (e.g., at time $t=0$). The particles **706** correspond to respective possible future locations of the vehicle **104**, although the specific further locations have not been determined yet. The particles **706** are based on vehicle trajectories **708** that correspond to the given location (e.g., from navigation system **214**).

[0087] At **710**, future positions of the particles are predicted to form predicted positions **712** (e.g., of the vehicle **104**). The predictions are based on the vehicle trajectories **708**. For example, the vehicle trajectories **708** may comprise speed and yaw rate information. The speed and yaw rates may be used to predict new poses for the respective runs **702** and thus, the predicted positions **712** of the particles **706**.

[0088] At **714**, particle weights **716** are updated. In order to do so, the particles **706** are projected onto the radar occupancy grid **308**, where each particle **706** has corresponding grid cells. The sum of all of the probability values (e.g., from the multiple runs **702**) in the corresponding grid cell is the weight of the particle **706**. In other words, the weight of a particle **706** corresponds to how well a next radar detection **304** fits the predicted position **712**.

[0089] At **718**, existing probabilities are updated using the particle weights **716** to create the radar occupancy probabilities **408**.

[0090] At **720**, the particles are resampled to create resampled particles **722**. Particles with high weights may be split, while particles with low weights may disappear. The resampled particles **722** become the particles at time $t+1$ for use in the position prediction (step **710**). The resampled particles **722** may also be used to correct the vehicle trajectories **708**.

[0091] As the time t is incremented, the radar occupancy probabilities **408** are updated, and the radar occupancy probabilities **408** are fused with previous radar occupancy probabilities per **410**.

[0092] One advantage of example illustrations **700** and **800** is that they build the radar occupancy probabilities **408** using data from the runs **702** simultaneously. As such, each set of particles **706** contains the same data for all the runs **702**. This means that the radar occupancy probability **408** for one particle **706** contains data from all of the runs **702**. Furthermore, the radar occupancy probabilities **408** are updated (e.g., at **718**) using more than one particle **706**. The statistical map fusion also allows for newer runs to be weighted more than older runs such that change detection (seasonal vegetation change, constructions, etc.) may be compensated on a cell level of the radar occupancy grid **308**.

[0093] By using the techniques of example illustrations **700** and **800**, accurate radar reference maps may be generated without using high-accuracy location data (e.g., by using consumer vehicles). As such, the radar reference maps are easier/more feasible to generate in a wider variety of locations.

[0094] FIG. 9 is an example illustration **900** of a method of determining the radar occupancy probabilities **408**. The example illustration **900** may be implemented utilizing the previously described examples, such as the example illustrations **700** and **800**. Operations **902** through **910** may be performed by one or more entities of the system **102** and/or the cloud system **202** (e.g., the radar-localization module **210**). The order in which the operations are shown and/or described is not intended to be construed as a limitation, and any number or combination of the operations can be combined in any order to implement the illustrated method or an alternate method.

[0095] At **902**, particles are created. For example, the radar-localization module **210** may receive radar detections **304** and create particles **706** that correspond to possible future locations of the vehicle **104** (or vehicles if the runs **702** correspond to multiple vehicles).

[0096] At **904**, particle positions are predicted for the particles. For example, the radar-localization module **210** may receive the vehicle trajectories **708** and determine the predicted positions **712**.

[0097] At **906**, particle weights of the particles are updated. For example, the radar-localization module **210** may determine the particle weights **716** based on radar detections **304** that correspond to a later time.

[0098] At **908**, probabilities are updated based on the particle weights. For example, the radar-localization module **210** may use the particle weights **716** to determine the radar occupancy probabilities **408** for fusing at **410**.

[0099] At **910**, the particles are resampled. For example, the radar-localization module **210** may create resampled particles **722** for predicting future positions at **710**.

[0100] FIG. 10 is an example illustration **1000** of generating the radar reference map **316** using low-accuracy location data and an HD map **1002**. The example illustration **1000** is generally implemented by the system **102**.

[0101] The HD map **1002** contains object attributes **1004** that are determined at **1006** for HD map objects **1008** within the HD map **1002**. The HD map objects **1008** may comprise street signs, overpasses, guard rails, traffic control devices, posts, buildings, k-rails, or other semi-permanent objects. The HD map **1002** contains information about each of the HD map objects **1008**.

[0102] Object attributes **1004** that may be determined at **1006** include aspects such as types **1010**, dimensions/orientations **1012**, locations **1014**, linkages to roads **1016** for the

respective HD map objects **1008**, and radar hardware information **1018**. The types **1010** may define the respective HD map objects **1008**, such as being street signs, overpasses, guard rails, traffic control devices, posts, buildings, k-rails, or other semi-permanent objects. The dimensions/orientations **1012** may comprise physical dimensions and/or orientations (e.g., portrait vs. landscape, rotation relative to the ground, height relative to the ground) of the respective HD map objects **1008**.

[**0103**] The locations **1014** may comprise UTM coordinates of the respective objects, and the linkages to roads **1016** may comprise specific locations of the respective objects relative to the corresponding roads. For example, a guardrail may have a certain offset relative to its cited location. In other words, the guard rail itself may not exist exactly at its location **1014**. The linkage to road **1016** may account for that. In some implementations, the linkage to road **106** may have a height or elevation aspect. For example, two objects may have similar coordinates but correspond to different roads. The height or elevation may be used to differentiate the two objects. The radar hardware information **1018** may comprise any information that affects a radar reflection **108** from the respective HD map object **1008**.

[**0104**] Unaligned radar detections **1020** are received, at **1022**, along with the object attributes **1004**. The unaligned radar detections **1020** are similar to the radar detections **304** with low-accuracy location data. The object attributes **1004** are used to determine vehicle poses **1024** for the vehicle **104** at the respective times of the unaligned radar detections **1020**.

[**0105**] In order to do so, the vehicle may localize itself relative to one or more of the HD map objects **1008** for each set of unaligned radar detections **1020**. For example, the respective set of unaligned radar detections **1020** may contain detections of the one or more HD map objects **1008**. Since the locations **1014** (and other object attributes **1004**) of the one or more HD map objects **1008** are known, the radar-localization module **210** can determine the vehicle pose **1024** at the respective set of unaligned radar detections **1020**.

[**0106**] Once the vehicle poses **1024** are known for the respective unaligned radar detections **1020**, the unaligned radar detections **1020** may be aligned at **1026**. The alignment may comprise shifting or rotating the unaligned radar detections **1020** based on the respective vehicle poses **1024**.

[**0107**] The aligned radar detections become the radar detections **304**. The radar detections **304** may then be used in example illustrations **300**, **400**, and **500** to generate the radar reference map **316**.

[**0108**] The radar reference map **316** may optionally be sent to the cloud system **202**. There, at **1028**, the radar reference map **316** may be updated based on, or compiled with, other radar reference maps based on other similar runs by the vehicle or other vehicles.

[**0109**] By using the techniques of example illustration **1000**, accurate radar reference maps may be generated without using high-accuracy location data (e.g., by using consumer vehicles). As such, the radar reference maps are easier/more feasible to generate in a wider variety of locations.

[**0110**] FIG. **11** is an example illustration **1100** of a method of generating the radar reference map **316** using low-accuracy location data and an HD map **1002**. The example

illustration **1100** may be implemented utilizing the previously described examples, such as the example illustration **1000**. Operations **1102** through **1110** are generally performed by the system **102**. The order in which the operations are shown and/or described is not intended to be construed as a limitation, and any number or combination of the operations can be combined in any order to implement the illustrated method or an alternate method.

[**0111**] At **1102**, unaligned radar detections are received. For example, the radar-localization module **210** may receive the unaligned radar detections **1020**.

[**0112**] At **1104**, HD map object attributes are determined. For example, the radar-localization module **210** may determine the object attributes **1004** for the HD map objects **1008** of the HD map **1002**.

[**0113**] At **1106**, vehicle poses are determined for each set of unaligned radar detections. For example, the radar-localization module **210** may determine the vehicle poses **1024** based on the unaligned radar detections **1020** and the object attributes **1004**.

[**0114**] At **1108**, the unaligned radar detections are aligned. For example, the radar-localization module **210** may use the vehicle poses **1024** to shift the unaligned radar detections **1020**. The aligned radar detections essentially become the radar detections **304**.

[**0115**] At **1110**, a radar reference map is generated. For example, the radar-localization module **210** may perform the example illustrations **300**, **400**, and **500** to generate the radar reference map **316** from the aligned radar detections (radar detections **304**).

[**0116**] Optionally, at **1112**, the radar reference map may be transmitted to a cloud system for updating. The updating may be based on similar reference maps generated by the vehicle or another vehicle. For example, the radar-localization module **210** of the cloud system **202** may modify or update the radar reference map **316** based on other similar radar reference maps received from the vehicle or other vehicles.

[**0117**] FIG. **12** is an example illustration **1200** of generating the radar reference map **316** using low-accuracy location data and the HD map **1002** (not shown). The example illustration **1200** is generally performed by the cloud system **202** based on information received from the system **102**.

[**0118**] At the system **102**, the unaligned radar detections **1020** are run through the example illustrations **300**, **400**, and **500** to generate an unaligned radar reference map **1202**. The unaligned radar reference map **1202** may be similar to the radar reference map **316**, except that the Gaussians **318** may not be in correct places (due to low-accuracy location data).

[**0119**] In some implementations, only a portion of example illustration **400** may be performed. For example, the steps up to step **410** may be performed to form individual occupancy grids for respective sets of unaligned radar detections **1020**, as the low-accuracy location data may not lend itself to fusing with other data to form a single radar occupancy grid (e.g., radar occupancy grid **308**). Each unaligned radar occupancy grid may then be used to form the unaligned radar reference map **1202**.

[**0120**] The unaligned radar reference map **1202** (e.g., with unaligned Gaussians that are similar to Gaussians **318**) is then sent to the cloud system **202**. At **1204**, the object attributes **1004** of the HD map **1002** are used by the cloud system **202** to align the unaligned radar reference map **1202** to generate the radar reference map **316**.

[0121] In order to do so, similarly to example illustration 1000, the object attributes 1004 are usable to align or change the Gaussians 318 within the unaligned radar reference map 1202. For example, the object attributes 1004 may be used to determine Gaussians 318 within the unaligned radar reference map 1202 that correspond to the corresponding HD map objects 1008. Since the locations of those objects are known, the Gaussians 318 can be shifted to correct locations.

[0122] If the unaligned radar detections 1020 are contiguous in space (e.g., they incrementally follow a path), then the unaligned radar reference map 1202 may have accurate locations of the Gaussians 318 relative to one another. In such a case, the unaligned radar reference map 1202 may only need to be shifted or rotated globally (instead of having to align each Gaussian 318).

[0123] The unaligned radar detections 1020 may also be sent to the cloud system 202 to process in a manner similar to example illustration 1000. The unaligned radar reference map 1202, however, is much smaller and therefore easier to transmit.

[0124] By using the techniques of example illustration 1200, accurate radar reference maps may be generated without using high-accuracy location data (e.g., by using consumer vehicles). As such, the radar reference maps are easier/more feasible to generate in a wider variety of locations.

[0125] FIG. 13 is an example illustration 1300 of a method of generating the radar reference map 316 using low-accuracy location data and an HD map 1002. The example illustration 1300 may be implemented utilizing the previously described examples, such as the example illustration 1200. Operations 1302 through 1306 are generally performed by the cloud system 202. The order in which the operations are shown and/or described is not intended to be construed as a limitation, and any number or combination of the operations can be combined in any order to implement the illustrated method or an alternate method.

[0126] At 1302, an unaligned radar reference map is received. For example, the radar-localization module 210 may receive the unaligned radar reference map 1202 from the system 102.

[0127] At 1304, HD map object attributes are determined. For example, the radar-localization module 210 may determine the object attributes 1004 for the HD map objects 1008 of the HD map 1002.

[0128] At 1306, the unaligned radar reference map is aligned based on the HD map object attributes. For example, the radar-localization module 210 may use the object attributes 1004 to determine Gaussians within the unaligned radar reference map 1202 that correspond to the associated HD map objects 1008. Differences between locations of the corresponding Gaussians and the HD map objects 1008 may then be used to correct, adjust, shift, or otherwise correct the unaligned radar reference map 1202 to form the radar reference map 316.

[0129] FIG. 14 is an example illustration 1400 of generating the radar occupancy grid 308 using the HD map 1002. The example illustration 1400 may be integrated with example illustrations 300 and 500 to generate the radar reference map 316. The example illustration 1400 does not need radar (e.g., radar reflections 108, radar detections 304) to create the radar occupancy grid 308. As will be apparent,

however, example illustration 1400 does rely on an availability of the HD map objects 1008 in the HD map 1002.

[0130] Similar to example illustrations 1000 and 1200, the object attributes 1004 of the HD map objects 1008 are determined. The object attributes 1004 are used to determine, at 1402, shapes 1404. The shapes 1404 are geometric representations of the HD map objects 1008 relative to the radar occupancy grid 308. The shapes 1404 may be lines, polylines, polygons, geometric shapes, curves, complex curves, or statistical representations. For example, a location, orientation, and specifics (e.g., offset) of a guardrail may be used to generate a shape 1404 of occupied spaces in the radar occupancy grid 308 that correspond to the guardrail.

[0131] At 1406, sizes of the respective shapes 1404 are compared to a grid size of the radar occupancy grid 308. If a shape 1406 is not longer than a grid cell of the radar occupancy grid 308, the corresponding grid cell is marked as being occupied.

[0132] If, however, a shape 1406 is longer than a grid cell, the shape 1406 is oversampled, at 1408, to create an oversampled shape 1410. The oversampling comprises adding more points along the respective shape 1404 to simulate a radar occupancy grid output from radar detections (e.g., from radar detections 304).

[0133] The shapes 1404 or the oversampled shapes 1410 are then adjusted (e.g., transformed) based on the object attributes 1004 or some other information, at 1412, to form adjusted shapes 1414. Continuing with the guardrail example above, the system may know that guardrails of a certain type are always some distance further away from an edge of the road than the location contained within the object attributes 1004. The adjusted shapes 1414 are used to mark corresponding grid cells of the radar occupancy grid 308 as occupied.

[0134] In some implementations, the shapes 1404 or the oversampled shapes 1410 may be used to determine the radar reference map 316 instead of the radar occupancy grid 308. In other words, the Gaussians 318 may be generated based on the shapes 1404 or the oversampled shapes 1400 without first generating the radar occupancy grid 308.

[0135] As shown in the example radar occupancy grid 308, the HD map objects 1008 (e.g., the guardrails) are represented as occupied spaces. In this way, the radar occupancy grid 308 may be generated without necessitating a vehicle driving through the corresponding area.

[0136] FIG. 15 is an example illustration 1500 of generating the radar occupancy grid 308 using the HD map 1002 and machine-learned models. The example illustration 1500 may be integrated with example illustration 1400 (e.g., to determine transformations for the adjusting at 1412). In some implementations, however, the machine-learned models may be used to indicate cells of the radar occupancy grid 308 directly (e.g., without example illustration 1400).

[0137] In example illustration 1500, the object attributes 1004 are used to select and apply models 1502 that are used to adjust the shapes at 1412. The models 1502 are based on respective object attributes 1004.

[0138] At 1504, a model 1502 is selected and applied to each HD map object 1008. The models 1502 are categorized by respective object attributes 1004. For example, a model 1502 may exist for each type of HD map object 1008 (e.g., model 1502-1 for a guardrail, model 1502-2 for a sign, model 1502-3 for a building, etc.). Multiple models 1502

may also exist for a single type of object. For example, different types of guardrails may have different respective models **1502**.

[0139] The models **1502** are previously generated and may be taught using machine learning on real-world occupancy grid data. For example, occupancy data (e.g., portions of that determined by example illustrations **300** and **400**) may be fed into a model training program along with object attributes **1004** and HD map locations of the corresponding HD map objects **1008**. In so doing, the system is able to form rules and dependencies that “learn” how to represent corresponding HD map objects **1008** in the radar occupancy grid **308** (e.g., through shape adjustments).

[0140] The output of the respective models **1502** is occupancy grid data **1506** that corresponds to shape adjustment data. The shape adjustment data may then be used to adjust the shapes **1404** of example illustration **1400**.

[0141] In some implementations, the occupancy grid data **1506** may comprise direct occupancy grid data. In such cases, shapes are not used, and the occupancy grid data **1506** is used as direct inputs to the radar occupancy grid **308** (e.g., the occupancy grid data **1506** is usable to indicate cells of the radar occupancy grid **308** as occupied).

[0142] As discussed above, the radar occupancy grid **308** can then be used to generate the radar reference map **316**. In this way, real-world radar occupancy data can be used to estimate adjustments or occupancy of HD map objects **608** for representation in the radar occupancy grid **308**.

[0143] By using the techniques of example illustrations **1400** and **1500**, accurate radar reference maps may be generated without using radar detections of the corresponding areas (although, in some implementations, they may be used to update the maps and/or provide additional map data). As such, the radar reference maps are easier/more feasible to generate for a wider variety of locations. Furthermore, the maps may be generated completely offline as long as the HD map has sufficient objects.

[0144] FIG. **16** is an example illustration **1600** of a method of generating the radar occupancy grid **308** using the HD map **1002**. The example illustration **1600** may be implemented utilizing the previously described examples, such as the example illustrations **1400** and **1500**. Operations **1602** through **1608** are generally performed by the cloud system **202** as there is no need for the vehicle **104**. The operations **1602** through **1608** (or portions thereof) may be performed by the system **102**, however. The order in which the operations are shown and/or described is not intended to be construed as a limitation, and any number or combination of the operations can be combined in any order to implement the illustrated method or an alternate method.

[0145] At **1602**, HD map object attributes are determined for HD map objects within an HD map. For example, the radar-localization module **210** may determine the object attributes **1004** for the HD map objects **1008** of the HD map **1002**.

[0146] At **1604**, shapes for the HD map objects are determined. In some implementations, the shapes may be over-sampled based on sizes of the respective shapes and a grid size of a desired radar occupancy grid. For example, the radar-localization module **210** may determine the shapes **1404** for the HD map objects **1008** and oversample the shapes **1404** if they are longer than a grid size of the radar occupancy grid **308**.

[0147] At **1606**, adjustments are applied to the shapes as needed. The adjustments may be based on the HD map object attributes or machine-learned models for the respective HD map objects. For example, the radar-localization module **210** may adjust the shapes **1404** based on the object attributes **1004** or the models **1502**.

[0148] At **1608**, cells of a radar occupancy grid are indicated as occupied based on the shapes. For example, the radar-localization module **210** may indicate cells of the radar occupancy grid **308** based on the shapes **1404** (after over-sampling and adjustment per **1406** and **1412**).

[0149] By performing one or more of the techniques described above, accurate and space efficient radar reference maps may be generated. In this way, accurate localization may be achieved to support driver assist or autonomous driving capabilities with limited driver takeover. Less driver takeover leads to increased safety and driver satisfaction.

[0150] Updating a Radar Reference Map

[0151] The following section describes techniques for updating a radar reference map. Constant improvement of the radar reference map is required because any particular environment through which a vehicle travels tends to change over time. The radar reference map may include temporary obstacles that may not be considered attributes, which may be added or removed. Additionally, a radar reference map may include false attribute data or missing attributes (e.g., occlusions in the radar reference map). Current techniques for updating the radar reference map often use different sensors gathering attribute data in a single traversal of an environment. The techniques described below use radar-centric data gathered from multiple iterations of traversing the environment to update the quality of the radar reference map. The techniques use a process to ensure accurate and stable data, referred to as hindsight; two non-limiting examples of which are illustrated. One example uses radar detections of objects and compares them with an HD map. The second example uses only radar detections in using hindsight as a way to ensure the data is accurate and stable.

[0152] FIG. **17** illustrates a flow chart **1700** for updating, through multiple iterations, a radar reference map used for vehicle localization based on radar detections. The flow chart includes multiple runs **1702** (e.g., run **1** to run **n** where **n** can be any integer greater than **1**), with each run being an iteration through an environment represented by a radar reference map. A first step **1704** of a radar-localization module (e.g., radar-localization module **210** from FIG. **2-1**) is to receive radar detections and navigation data. In a step **1706**, the radar detections and navigation data may be used by a static object identifier to identify static objects from the raw radar detections and navigation data collected in step **1704**. A step **1708** generates an occupancy grid based on the static objects identified in step **1706**. In a step **1710**, a radar reference map is built from each occupancy grid generated in each run **1702**. A final step **1712** builds (in the initial run **1**) and updates (in each successive run **n**) a relative NDT radar reference map (e.g., a map relative to the vehicle and using a relative coordinate system) based on the radar reference map generated in step **1710**. The final step **1710** is conditioned on an HD map **1714** not being utilized in step **1710** in combination with the occupancy grids generated in step **1708**. Otherwise if the HD map **1714** is utilized in step **1710**, the final step **1712** updates an absolute map (e.g., a universal map using a global coordinate system such as the UTM coordinate system) during each run **1702**.

[0153] FIG. 18 illustrates an example implementation 1800 of updating, through multiple iterations, a radar reference map used for vehicle localization based on radar detections. In the example implementation 1800, a vehicle 1802 equipped with a radar-localization module (e.g., onboard, accessed through a cloud) uses hindsight to accumulate accurate and stable radar data about a dynamic object 1804. Radar sensors on the vehicle 1802 have radar sweeps 1806 that transmit electromagnetic energy and receive the reflections of the electromagnetic energy off of objects. The radar sweeps 1806 may not be illustrated to scale in FIG. 18 or in any of the other figures in which they are depicted. The dynamic object 1804 is moving from in front (dynamic object 1804-1) of the vehicle 1802 to beside (dynamic object 1804-2) the vehicle 1802 to behind (dynamic object 1804-3) the vehicle 1802. A blind spot 1808 represents a range-rate blind spot of one or more radar sensors on the vehicle 1802. Although in the example implementation 1800, the blind spot 1808 is related to the range rate state of the dynamic object, any dynamic state of the dynamic object 1804 may be used as an example.

[0154] Corner radar sensors mounted on the vehicle 1802 are configured such that the bore angles of the radar sensors are 45° in relation to the longitudinal axis of the vehicle 1802. This enables the corner radar sensors to have the same radar performance as the front and rear radar sensors of the vehicle 1802. The accumulated data from all the radar sensors present the most stable results of object detection at the rear of the vehicle 1802 with the dynamic object 1804 reflecting several radar detections from the different radar sensors. As an occupancy grid presents accumulated data, all available sensor detections contribute to a radar reference map even if the rear detection is the only one taken into consideration. The detections from all the radar sensors contribute to the occupancy probability, and none of the radar data are omitted. This process may be interpreted as an application of binary weights for each cell of the occupancy grid, and the dynamic object 1804 may be excluded from the updated radar reference map.

[0155] FIG. 19 illustrates a pipeline 1900 for updating, through multiple iterations, a radar reference map used for vehicle localization based on radar detections. At a radar sensor stage 1902 of the pipeline 1900, a radar sensor 1904 receives raw radar detections 1906. At a static object identifier 1908 stage, the raw radar detections 1904 are classified at 1910 as static or dynamic radar detections, and augmented static radar detections 1912 are passed to an occupancy grid generator 1914 stage. In the occupancy grid generator 1914 stage, occupancy evidence from the augmented static radar detections 1912 is extracted at 1916. At 1918, the extracted occupancy evidence from 1916 is used to accumulate and filter static occupancy on an occupancy grid 1920. An accumulator 1922 stage then extracts hindsight information at 1924.

[0156] FIGS. 20-1 to 20-3 illustrate an example implementation of hindsight used to update, through multiple iterations, a radar reference map used for vehicle localization based on radar detections. In FIG. 20-1, a vehicle 2002, equipped with a radar-localization module (e.g., onboard, accessed through a cloud) uses hindsight to accumulate accurate and stable radar data about a static object 2004 (a street sign 2004). In a first time frame 2000-1 in FIG. 20, the street sign 2004 may be detected first by radar sweeps

2006-1 and 2006-2. Radar sweeps 2006-3 and 2006-4 have not yet detected the street sign 2004.

[0157] In a second time frame 2000-2 in FIG. 20-2, the vehicle 2002 has moved down the road, and the street sign 2004 is lateral to the vehicle 2002. At least radar sweeps 2006-1, 2006-2, and possibly radar sweep 2006-3 have detected the street sign 2004. Additionally, radar sweeps 2006-1 and 2006-2 may have detected a second static object 2008 (a tree 2008).

[0158] In a third time frame 2000-3 in FIG. 20-3, the vehicle 2002 has moved forward such that the street sign 2004 has been detected by radar sweeps 2006-1, 2006-2, 2006-3, and 2006-4, accumulatively. At this point, the street sign is in hindsight of the radar sweeps, and the radar data relative to the street sign may be considered stable and accurate with a high confidence level. At least radar sweeps 2006-1, 2006-2, and possibly radar sweep 2006-3 have detected the tree in time frame 2000-3 and have a moderate confidence level, but higher than a third static object 2010 (a guard rail 2010). Only sweeps 2006-1 and 2006-2 may have detected the guard rail 2010.

[0159] Driving on the road in the depictions 2000-1 to 2000-3 over multiple iterations may increase the confidence level that the static objects 2004, 2008, and 2010 are permanent and can be considered attributes. If any of the static objects 2004, 2008, and 2010 disappear during any of the multiple iterations of runs down the road, the confidence level for that object may fall, and the object may be removed from the updated radar reference map. Furthermore, consider a moving vehicle traveling in another direction (e.g., in a lane adjacent to the vehicle 2002). Conventional techniques may consider the moving vehicle when it is immediately adjacent to the vehicle 2002. By using hindsight, the moving vehicle will not be considered. In this manner, the radar reference map may be updated after each iteration to add or remove attributes as they are detected or disappear, and to remove any spurious noise that may be present in the radar reference map.

[0160] FIG. 21 illustrates an example process 2100 to determine and use a hindsight maximum boundary for radar coordinates when updating, through multiple iterations, a radar reference map used for vehicle localization based on radar detections. There are two options for radar coordinates, radar relative coordinates, and radar absolute coordinates. At 2102, all radar reference maps are loaded. Additionally, if using radar absolute coordinates, at 2104, sample points from one or more HD maps are extracted, and at 2106, the extracted sample points are transformed into a statistical distribution. At 2108, all of the hindsight samples are collected, and a minimum and maximum for the coordinates (X and Y) are found. At 2110, the minimum and maximum for the coordinates are used to create a maximum boundary for a new radar group. At 2112, a resolution is chosen, and an index of the samples in the resolution of the coordinates index is checked. At 2114, based on the outcomes of the check procedure at 2112, if the sample is not new in the chosen resolution, then at 2116, only the log-odds ratios, by either Bayes Inverse Model or by maximum policy, are merged into the radar reference maps. If, at 2114, the sample is new in the chosen resolution, then at 2118, the original index of the new sample is added into a new map index.

[0161] Example Architecture

[0162] Applying the techniques discussed in this document to localize a vehicle based on radar detections may have many advantages. By using radar-centric systems (e.g., a radar system including four short-range radar sensors, one radar sensor located at each of the four corners of a vehicle), adverse weather and lighting conditions that may degrade the effectiveness of other systems (e.g., cameras, LiDAR) are overcome by only using radar systems. Additionally, the radar systems used may be less expensive than some other sensor systems.

[0163] The techniques and systems described in this document enable a vehicle to determine its vehicle pose, or location, at a sub-meter accuracy level. To localize a vehicle based on radar detections, according to the techniques described herein, two steps may be performed, including steps to: construct an accurate radar reference map, and compare the radar reference map against radar detections generated in real time to accurately locate the vehicle. FIGS. 22-1 and 22-2 describe one detailed example of how to achieve these two steps with a radar-localization module, such as the radar-localization module illustrated in FIGS. 2-2 and 2-3. Other examples may preclude some of the details in FIGS. 22-1 and 22-2 (e.g., some submodules of the radar-localization module are optional, as illustrated in FIGS. 2-2 and 2-3).

[0164] FIGS. 22-1 to 22-2 illustrate an example flow diagram 2200 of a process for vehicle localization based on radar detections. FIG. 22-1 covers the first step as flow diagram 2200-1, and FIG. 22-2 covers the second step as flow diagram 2200-2. The sub-steps within a dashed box 2202 of FIG. 22-1 and FIG. 22-2 are identical in each step.

[0165] The first step of vehicle localization 2204 is to construct an accurate radar reference map containing attribute information. Details of several different processes of constructing the radar reference map have been described above. The example flow diagram illustrated in FIG. 22-1 details the architecture of constructing the radar reference map in the vehicle 2204-1 specially equipped with a high-quality navigation system. The radar-localization module is in a reference mode for this step.

[0166] In the example flow diagram illustrated in FIG. 22-1, one or more radar sensors 2206 receive raw radar detections 2208. Simultaneously, high-quality GNSS 2210-1 and inertial measurement unit (IMU) 2212-1 data are collected by a vehicle state estimator 2214 to determine the vehicle state and vehicle pose. The raw radar detections 2208 are collected at a certain rate, for example, every 50 milliseconds (ms). The raw radar detections 2208 are identified as static detections or dynamic detections by a static object identifier 2216. The static object identifier 2216 uses vehicle state information (e.g., range rate) provided by the vehicle state estimator 2214 to determine (e.g., determine through range rate de-aliasing) the identification of the raw radar detections 2208.

[0167] The static detections are output to an occupancy grid generator 2218. The occupancy grid generator 2218 estimates an occupancy probability for each cell (e.g., 20 centimeters (cm) by 20 cm cell) in the occupancy grid. The cell size may impact the processing time for this sub-step. Different processes, including Bayesian inference, Dempster Shafer theory, or other processes, can be used to estimate the occupancy probability for each cell. The occupancy grid generated by the occupancy grid generator 2218 may be in

relative coordinates (e.g., local frame of reference) to the vehicle 2204-1 as the occupancy grid generator 2218 receives vehicle state data from the vehicle state estimator 2214 that assists in the creation of the occupancy grid.

[0168] A scan-matcher 2220 performs a series of sub-steps 2220-1 to 2220-4. Sub-step 2220-1 transforms the occupancy grid from a relative coordinate system to a UTM coordinate system. Vehicle state information from the vehicle state estimator 2214 is used in the transformation process. Sub-step 2220-2 accumulates occupancy grid outputs from sub-step 2220-1 at a certain rate (e.g., 10 Hz). The rate may be tuned based on a driving scenario (e.g., quantity of attributes in the environment of the vehicle 2204-1) and outputs the accumulated occupancy grid to sub-step 2220-3. Sub-step 2220-3 chooses occupancy grid cells based on a high-occupancy probability (e.g., a probability equal to or greater than 0.7). The chosen occupancy grid cells may be represented as a point cloud. Sub-step 2220-4 transforms the chosen occupancy grid cells in a Gaussian representation to create a Gaussian, or NDT, radar reference map. The NDT radar reference map can be stored locally on the vehicle 2204-1 or uploaded to a cloud 2222.

[0169] The second step of vehicle localization 2204 is to determine an adjusted vehicle pose based on a comparison of radar detections of attributes with a radar reference map. The example flow diagram in FIG. 22-2 details the architecture used to determine this adjusted vehicle pose for the vehicle 2204-2. It can be assumed in this example that the vehicle 2204-2 is configured as a non-luxury vehicle manufactured in mass quantities and at cost margins that make using high-quality GNSS and sensor packages not practical. That is, the GNSS system 2210-2 and the IMU 2212-2 used in the vehicle 2204-2 may be considered average (lower quality) commercial navigation systems. The radar-localization module is in a real-time localization mode for the second step. All of the sub-steps inside the dashed box 2202 are identical to those of the first step illustrated in FIG. 22-1 and, for simplicity, will not be covered again.

[0170] At step 2224, a radar reference map, based on the vehicle state as determined by the vehicle state estimator 2214, is downloaded from the cloud 2222. The radar reference map is compared to the chosen occupancy grid cells at sub-step 2220-5, and based on that comparison, the vehicle pose is corrected for the vehicle 2204-2. A confidence level of an accuracy of the corrected pose may be used in determining the accuracy of the corrected pose. Additionally, the corrected vehicle pose may be used to remove errors (e.g., drift) in the GNSS system 2210-2 and the IMU 2212-2.

[0171] The comparison process matches the radar reference map, the radar reference map being a set of Gaussian representations that minimize memory size of the data and contain statistical information, with a real-time “map” that is derived from real-time radar detections. The real-time map is a sub-section of the area represented by the radar reference map and contains the same Gaussian-type statistical information as the radar reference map. In another implementation, the filtered outputs from the occupancy grid may be directly compared to the Gaussians in the radar reference map.

[0172] The NDT process matches statistical probability distributions between reference data (e.g., discretized cells with a built-in statistical model). For any given transformation (e.g., x, y, and rotation) for real-time points (e.g., occupancy grid outputs), the real-time points can be

assigned to discretized NDT cells that contain the statistical distribution in a model from the radar reference map. The real-time points are occupancy grid cells that are considered occupied but are treated as points with a probability value attached to the points. Probability distributions of the real-time points can therefore be calculated. The NDT process finds an optimal transformation that maximizes the probability distributions.

[0173] FIG. 23 illustrates an example process 2300 for vehicle localization based on radar detections. At 2302, radar detections are received by at least one or more processors of a vehicle. At 2304, navigation data is received by at least one or more processors of a vehicle. At 2306, Ego-trajectory information about a current dynamic state of the vehicle is output by at least one or more processors of the vehicle. This ego-trajectory information may include at least one of direction of travel, velocity, range rate, and yaw rate, as determined from the radar detections and navigation data. At 2308, attribute data is extracted from the radar detections and the ego-trajectory information. At 2310, a normal distribution transformation grid is determined from the extracted attribute data and a radar reference map. At 2312, a vehicle pose is corrected according to the normal distribution transformation grid to localize the vehicle.

[0174] In this manner, the techniques and systems described herein use cost-effective systems, disregard dynamic objects, maximize a statistical distribution pattern, and handle static noise efficiently to accurately adjust the pose of a vehicle.

EXAMPLES

[0175] Example 1: A method comprising: receiving a high-definition (HD) map; determining one or more HD map objects within the HD map; determining attributes of the respective HD map objects; and for each HD map object: indicating one or more occupancy cells of a radar occupancy grid as occupied space based on the attributes of the respective HD map object.

[0176] Example 2: The method of example 1, further comprising generating a radar reference map based on the radar occupancy grid, wherein the radar reference map comprises statistical representations of the occupancy cells of the radar occupancy grid that are indicated as occupied space.

[0177] Example 3: The method of example 1 or 2, wherein the attributes comprise one or more of a type, location, dimensions, orientation, linkage to a corresponding road, or radar hardware information for the respective HD map object.

[0178] Example 4: The method of any preceding example, wherein the method is performed by a cloud system that is external to a vehicle.

[0179] Example 5: The method of any preceding example, further comprising forming a shape for the respective HD map object, wherein the indicating is based on the shape.

[0180] Example 6: The method of any preceding example, further comprising applying an adjustment to the shape based on the attributes of the respective HD map object to form an adjusted shape, wherein the indicating is based on the adjusted shape.

[0181] Example 7: The method of any preceding example, further comprising determining if the shape is longer than one of the occupancy cells, wherein the indicating is based

on the shape responsive to determining that the shape is not longer than one of the occupancy cells.

[0182] Example 8: The method of any preceding example, further comprising, responsive to determining that the shape is longer than one of the occupancy cells, oversampling the shape to form an oversampled shape, wherein the indicating is based on the oversampled shape.

[0183] Example 9: The method of any preceding example, further comprising selecting a model for the respective HD map object from a plurality of models corresponding to respective types or attributes of HD map objects, wherein the adjustment is based on the model.

[0184] Example 10: The method of any preceding example, further comprising: inputting the attributes of the respective HD map object into the model; and receiving an output from the model, wherein the adjustment is based on the output from the model.

[0185] Example 11: A method comprising: receiving a high-definition (HD) map; determining one or more HD map objects within the HD map; determining attributes of the respective HD map objects; and for each HD map object: forming a Gaussian for each of one or more radar reference map cells based on the attributes of the respective HD map object.

[0186] Example 12: A system comprising: at least one processor; and at least one computer-readable storage medium comprising instructions that, when executed by the processor, cause the system to: receive a high-definition (HD) map; determine one or more HD map objects within the HD map; determine attributes of the respective HD map objects; and for each HD map object: indicate occupancy cells of a radar occupancy grid as occupied space based on the attributes of the respective HD map object.

[0187] Example 13: The system of example 12, wherein: the instructions further cause the system to generate a radar reference map based on the radar occupancy grid; and the radar reference map comprises statistical representations of the occupancy cells of the radar occupancy grid that are indicated as occupied space.

[0188] Example 14: The system of example 12 or 13, wherein the attributes comprise one or more of a type, location, dimensions, orientation, or linkage to a corresponding road for the respective HD map object.

[0189] Example 15: The system of any of examples 12 to 14, wherein: the instructions further cause the system to form a shape for the respective HD map object; and the indication is based on the shape.

[0190] Example 16: The system of any of examples 12 to 15, wherein: the instructions further cause the system to apply an adjustment to the shape based on the attributes of the respective HD map object to form an adjusted shape; and the indication is based on the adjusted shape.

[0191] Example 17: The system of any of examples 12 to 16, wherein: the instructions further cause the system to determine if the shape is longer than one of the occupancy cells; and the indication is based on the shape responsive to determining that the shape is not longer than one of the occupancy cells.

[0192] Example 18: The system of any of examples 12 to 17, wherein: the instructions further cause the system to, responsive to determining that the shape is longer than one of the occupancy cells, oversample the shape to form an oversampled shape; and the indication is based on the oversampled shape.

[0193] Example 19: The system of any of examples 12 to 18, wherein: the instructions further cause the system to select a model for the respective HD map object; and the adjustment is based on the model.

[0194] Example 20: The system of any of examples 12 to 19, wherein: the instructions further cause the system to: input the attributes of the respective HD map object into the model; and receive an output from the model; and the adjustment is based on the output from the model.

CONCLUSION

[0195] Although implementations for radar reference map generation have been described in language specific to certain features and/or methods, the subject of the appended claims is not necessarily limited to the specific features or methods described. Rather, the specific features and methods are disclosed as example implementations for radar reference map generation. Further, although various examples have been described above, with each example having certain features, it should be understood that it is not necessary for a particular feature of one example to be used exclusively with that example. Instead, any of the features described above and/or depicted in the drawings can be combined with any of the examples, in addition to or in substitution for any of the other features of those examples.

What is claimed is:

1. A method comprising:
 - receiving a high-definition (HD) map;
 - determining one or more HD map objects within the HD map;
 - determining attributes of the respective HD map objects; and
 for each HD map object:
 - indicating one or more occupancy cells of a radar occupancy grid as occupied space based on the attributes of the respective HD map object.
2. The method of claim 1, further comprising generating a radar reference map based on the radar occupancy grid, wherein the radar reference map comprises statistical representations of the occupancy cells of the radar occupancy grid that are indicated as occupied space.
3. The method of claim 1, wherein the attributes comprise one or more of a type, location, dimensions, orientation, linkage to a corresponding road, or radar hardware information for the respective HD map object.
4. The method of claim 1, wherein the method is performed by a cloud system that is external to a vehicle.
5. The method of claim 1, further comprising forming a shape for the respective HD map object, wherein the indicating is based on the shape.
6. The method of claim 5, further comprising applying an adjustment to the shape based on the attributes of the respective HD map object to form an adjusted shape, wherein the indicating is based on the adjusted shape.
7. The method of claim 5, further comprising determining if the shape is longer than one of the occupancy cells, wherein the indicating is based on the shape responsive to determining that the shape is not longer than one of the occupancy cells.
8. The method of claim 7, further comprising, responsive to determining that the shape is longer than one of the occupancy cells, oversampling the shape to form an oversampled shape, wherein the indicating is based on the oversampled shape.

9. The method of claim 6, further comprising selecting a model for the respective HD map object from a plurality of models corresponding to respective types or attributes of HD map objects,

wherein the adjustment is based on the model.

10. The method of claim 9, further comprising:

- inputting the attributes of the respective HD map object into the model; and
- receiving an output from the model,

 wherein the adjustment is based on the output from the model.

11. A method comprising:

- receiving a high-definition (HD) map;
- determining one or more HD map objects within the HD map;
- determining attributes of the respective HD map objects; and

 for each HD map object:

- forming a Gaussian for each of one or more radar reference map cells based on the attributes of the respective HD map object.

12. A system comprising:

- at least one processor; and
- at least one computer-readable storage medium comprising instructions that, when executed by the processor, cause the system to:
 - receive a high-definition (HD) map;
 - determine one or more HD map objects within the HD map;
 - determine attributes of the respective HD map objects; and

 for each HD map object:

- indicate occupancy cells of a radar occupancy grid as occupied space based on the attributes of the respective HD map object.

13. The system of claim 12, wherein:

- the instructions further cause the system to generate a radar reference map based on the radar occupancy grid; and

 the radar reference map comprises statistical representations of the occupancy cells of the radar occupancy grid that are indicated as occupied space.

14. The system of claim 12, wherein the attributes comprise one or more of a type, location, dimensions, orientation, or linkage to a corresponding road for the respective HD map object.

15. The system of claim 12, wherein:

- the instructions further cause the system to form a shape for the respective HD map object; and
- the indication is based on the shape.

16. The system of claim 15, wherein:

- the instructions further cause the system to apply an adjustment to the shape based on the attributes of the respective HD map object to form an adjusted shape; and
- the indication is based on the adjusted shape.

17. The system of claim 15, wherein:

- the instructions further cause the system to determine if the shape is longer than one of the occupancy cells; and
- the indication is based on the shape responsive to determining that the shape is not longer than one of the occupancy cells.

- 18.** The system of claim **15**, wherein:
the instructions further cause the system to, responsive to
determining that the shape is longer than one of the
occupancy cells, oversample the shape to form an
oversampled shape; and
the indication is based on the oversampled shape.
- 19.** The system of claim **16**, wherein:
the instructions further cause the system to select a model
for the respective HD map object; and
the adjustment is based on the model.
- 20.** The system of claim **19**, wherein:
the instructions further cause the system to:
input the attributes of the respective HD map object
into the model; and
receive an output from the model; and
the adjustment is based on the output from the model.

* * * * *