

(19)



(11)

EP 3 415 945 A1

(12)

EUROPEAN PATENT APPLICATION

(43) Date of publication:
19.12.2018 Bulletin 2018/51

(51) Int Cl.:
G01S 13/58 (2006.01) G01S 13/93 (2006.01)
G01S 7/295 (2006.01)

(21) Application number: 17175548.1

(22) Date of filing: 12.06.2017

(84) Designated Contracting States:
AL AT BE BG CH CY CZ DE DK EE ES FI FR GB
GR HR HU IE IS IT LI LT LU LV MC MK MT NL NO
PL PT RO RS SE SI SK SM TR

Designated Extension States:

BA ME

Designated Validation States:

MA MD

- STACHNIK, Mateusz
32-420 Gdow (PL)
- KOGUT, Krzysztof
30-689 Krakow (PL)

(74) Representative: Robert, Vincent et al
Aptiv Services France SAS
Aptiv EMEA Patent Department
Bâtiment Le Raspail - Paris Nord 2
22, avenue des Nations
CS 65059 Villepinte
95972 Roissy CDG Cedex (FR)

(71) Applicant: Aptiv Technologies Limited
St. Michael (BB)

(72) Inventors:
• CIESLAR, Dariusz
30-392 Krakow (PL)

(54) METHOD OF DETERMINING THE YAW RATE OF A TARGET VEHICLE

(57) A method of determining the yaw rate ($\hat{\omega}_t$) of a target vehicle in a horizontal plane by a host vehicle equipped with a radar system, said radar system including a radar sensor unit adapted to receive signals emitted from said host vehicle by said target, comprising: emitting a radar signal at a single time-point instance and determining from a plurality (m) of point radar detections measurements captured from said target vehicle by said radar sensor unit in said single radar measurement instance, the values for each point detection of range, azimuth and range rate; $[r_i, \theta_i, \dot{r}_i]$; determining the values of the longitudinal and lateral components of the range rate equation of the target (c_t, s_t) from the results (r_i, θ_i) and the sensor unit or host vehicle longitudinal velocity and v_s is the sensor unit or host vehicle lateral velocity; determining the orientation angle of the target ($\gamma_{t,scs}$); determining the target centre (x_t and y_t) from the results (r_i, θ_i); determining a line l_{PH} perpendicular to the orientation of the target and passing through the center of the target ($x_{t,c,scs}, y_{t,c,scs}$); determining a line l_{CA} passing through the center of rotation of said target and the position of radar sensor unit of said vehicle; determining the intersection point of the lines l_{CA} and l_{PH} being the position of the center of rotation $[\hat{x}_{t,COR}, \hat{y}_{t,COR}]$ of the target; h) estimating and yaw rate ω_t from the position of the centre of rotation found in step f) and components of range rate equation of the target (c_t or s_t) of step b).

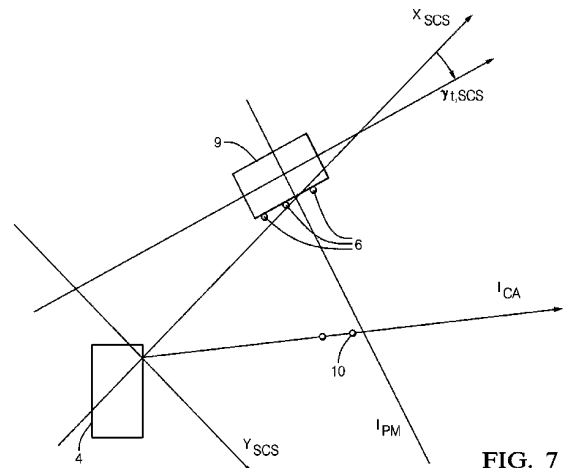

FIG. 7

EP 3 415 945 A1

Description

TECHNICAL FIELD

5 **[0001]** This disclosure generally relates to a radar system suitable for an automated vehicle, and more particularly relates to a system that calculates a yaw-rate of the target. This invention relates to a vehicle on-board method of estimation of planar motion parameters of objects (targets such as another vehicle) detected by a (e.g. Doppler) radar. It has particular application to detected the planar motion parameters of a vehicle by a host vehicle equipped with a radar system.

10

BACKGROUND OF THE INVENTION

[0002] Aspects of the invention relate to an improved method of determining the instantaneous values of lateral velocity, longitudinal velocity and yaw rate of any point of a rigid body in the radar field-of-view (FOV). Aspects are applicable (but not limited) to the estimation of vehicles for automotive perception systems and can be used in Active Safety, Driver Assistance and Autonomous Driving applications.

15

[0003] When an automated or autonomous host-vehicle is preceded by a target-vehicle traveling forward of the host-vehicle, it is advantageous for the system that controls the operation (e.g. steering, brakes, engine) of the host-vehicle to have knowledge of the yaw-rate of the target vehicle. Knowledge of the yaw-rate of the target vehicle can be useful to, for example, temporarily allow a closer following distance because the target-vehicle is turning out of the travel path of the host-vehicle.

20

[0004] In prior art, no algorithm was reported for an instantaneous estimation of full planar motion of rigid body target objects based on raw detections of a single radar.

25

SUMMARY OF THE INVENTION

[0005] In one aspect is provided a method of determining the yaw rate ($\hat{\omega}_t$) of a target vehicle in a horizontal plane by a host vehicle equipped with a radar system, said radar system including a radar sensor unit adapted to receive signals emitted from said host vehicle by said target, comprising:

30

a) emitting a radar signal at a single time-point instance and determining from a plurality (m) of point radar detections measurements captured from said target vehicle by said radar sensor unit in said single radar measurement instance, the values for each point detection of range, azimuth and range rate; $[r_p, \theta_p, \dot{r}_p]$

35

b) determining the values of the longitudinal and lateral components of the range rate equation of the target (c_t, s_t) from the results (\dot{r}_p, θ_p) of step a); where the range rate equation is

40

$$\dot{r}_{i,comp} = [\cos \theta_i \quad \sin \theta_i] \begin{bmatrix} c_t \\ s_t \end{bmatrix}$$

where $\dot{r}_{i,comp} = \dot{r}_i + u_s \cos \theta_i + v_s \sin \theta_i$ where u_s is the sensor unit or host vehicle longitudinal velocity and v_s is the sensor unit or host vehicle lateral velocity;

45

c) determining the orientation angle of the target ($\gamma_{t,scs}$);

d) determining the target centre (x_t and y_t) from the results (r_p, θ_p) of step a);

50

e) determining a line l_{PH} perpendicular to the orientation of the target and passing through the center of the target ($x_{t,c,scs}, y_{t,c,scs}$) from the results of step (c) and (d);

f) determining a line l_{CA} passing through the center of rotation of said target and the position of radar sensor unit of said vehicle; from the steps of b)

55

g) determining the intersection point of the lines l_{CA} and l_{PH} from steps e) and f) being the position of the center of rotation $[x_{t,COR}, y_{t,COR}]$ of the target;

h) estimating and yaw rate $\hat{\omega}_t$ from the position of the centre of rotation found in step g) and components of range

rate equation of the target (c_t or s_t) of step b).

[0006] Step c) may comprise determining the orientation angle of the target ($\gamma_{t,scs}$); from the values of range and azimuth (r_i θ_i) of said point detections.

5 [0007] Step c) may comprise determining the orientation angle of the target ($\gamma_{t,scs}$); from L fit, Hough transform or rotating caliper methodology from the results of of step a);

[0008] Step b) may include estimating components of range rate equation of the target (c_t , s_t) said point detection measurements of azimuth and range rate [θ_i , r_i].

[0009] Said estimating may comprise applying a Least Square method.

10 [0010] Said line l_{PH} of step e) may be determined and defined from the following equation:

$$: y = -\frac{1}{\tan \gamma_{t,scs}} x + \frac{1}{\tan \gamma_{t,scs}} x_{t,c,scs} + y_{t,c,scs} = a_1 x + a_0$$

15

[0011] Said line l_{CA} of step f) may be determined and defined from the following equation

$$: y = -\frac{\tilde{s}_{t,scs}}{\tilde{c}_{t,scs}} x = b_1 x + b_0$$

20

[0012] In step g) the position of the center of rotation [$\hat{x}_{t,COR}$, $\hat{y}_{t,COR}$] of the target may be determined from the following equations:

25

$$\hat{x}_{t,COR,scs} = \frac{b_0 - a_0}{a_1 - b_1} \quad \text{and,} \quad \hat{y}_{t,COR,scs} = \frac{a_1 b_0 - a_0 b_1}{a_1 - b_1}$$

[0013] In step h) the yaw rate may be determined from the following equations:

30

$$\hat{\omega}_t = \frac{\tilde{s}_{t,scs}}{-\hat{x}_{t,COR,scs}}$$

35 or

$$\hat{\omega}_t = \frac{\tilde{c}_{t,scs}}{\hat{y}_{t,COR,scs}}$$

40

[0014] The method may include additionally determining estimates of longitudinal velocity $\hat{u}_{t,i}$, lateral velocity $\hat{v}_{t,i}$ of certain target point from the value of yaw rate and the co-ordinates of the centre of rotation of the target ($y_{t,COR,wcs}$ $x_{t,COR,wcs}$) using the following equation;

45

$$\begin{bmatrix} \hat{u}_{t,i,scs} \\ \hat{v}_{t,i,scs} \end{bmatrix} = \begin{bmatrix} (\hat{y}_{t,COR,scs} - y_{t,i,scs}) \hat{\omega}_t \\ (x_{t,i,scs} - \hat{x}_{t,COR,scs}) \hat{\omega}_t \end{bmatrix}$$

BRIEF DESCRIPTION OF THE DRAWINGS

50

[0015] The present invention is now described by way of example with reference to the accompanying drawings in which:

- Figure 1 shows a target co-ordinate system;
- 55 - Figure 2 shows a vehicle coordinate system;
- Figure 3 shows a sensor coordinate system;
- Figure 4 illustrates how to calculate velocity vectors at the locations of three raw detections;
- Figure 5 which shows the result of the cloud algorithm for yawing targets;

- Figure 6 shows an example of the determination of target orientation based on spatial distribution of raw detections;
- Figure 7 illustrates a geometrical interpretation of one method;
- Figure 8 shows an example of test results of a maneuver;
- Figures 9a to d illustrate the movement relating to figure 8;
- 5 - Figure 10 shows an example of test results of a maneuver;
- Figures 11a to d illustrate the movement relating to figure 10;
- Figure 12 shows an example of test results of a maneuver;
- Figures 13a to d illustrate the movement relating to figure 12.

10 Prior Art and Background

[0016] Accurate estimation of the yaw-rate and over-the-ground (OTG) velocity is important for many driving-assistance systems. Described herein is a radar system configured to estimate the yaw-rate and OTG velocity of extended targets (largely, for vehicle tracking) in real-time based on raw radar detections (i.e., range, range-rate, and azimuth). As used
 15 herein, the term 'extended-targets' is used to refer to targets that present multiple, spaced-apart scattering-points so the term 'extended-target' is understood to mean that the target has some physical size. The various scattering-points are not necessarily individually tracked from one radar scan to the next, so the number of scatter-points can be a different quantity and/or each scattering point have a different location on the extended-target in successive radar scans.

[0017] The invention determines instantaneous values of lateral velocity, longitudinal velocity and yaw rate of any point of a rigid body (such as another vehicle) in the radar field-of-view (FOV). Generally a host vehicle is equipped with a radar system where reflected radar signals (detection) from another vehicle in the field of view are processed to provide data in order to ascertain these parameters. In order to do this various conditions and requirements are needed. The target (rigid body/vehicle) needs to be a distributed target, i.e. provide a plurality of detections from the same target.

[0018] Also assumed is an approximation of the distributed target by a rigid body model which is e.g. appropriate for vehicles (passenger cars, trucks, motorbikes, trains, trams, etc.), though not generally applicable to vulnerable road users.

[0019] Radar detections received by the host vehicle form the target provide raw data provide data with respect to the position of the radar transmit/receive element/unit e.g. the Cartesian position of the detections or the Polar co-ordinates (azimuth angle, range). By using e.g. Doppler techniques, the range rate can also be determined.

[0020] In the subsequent concept description the following conventions and definitions are used:

30 World coordinate system

[0021] As is convention an inertial coordinate system with the origin fixed to a point in space is used - it is assumed the co-ordinate system does not move and does not rotate. Conventionally the coordinate system is right-handed; the
 35 Y-axis orthogonal to the X-axis, pointing to the right; the Z-axis pointing into the page and positive rotation is to the right of the X-axis; see figure 1 which shows such a co-ordinate system with origin 1 and a non-ego vehicle (target) 2.

Vehicle coordinate system

[0022] The origin may be located at the center of the front bumper 3 of the host vehicle 4 as shown by figure 2. The
 40 X-axis is parallel to the longitudinal axis of the vehicle. The coordinate system is right-handed with the Y-axis orthogonal to the X-axis, pointing to the right, the Z-axis pointing into the page and positive rotation to the right of the X-axis

Sensor coordinate system

[0023] Origin located at the center of the sensor unit/radome. The X-axis is perpendicular to the sensor radome, pointing away from the radome. The coordinate system is right-handed: Y-axis orthogonal to the X-axis, pointing to the right; Z-axis pointing into the page; Positive rotation to the right of the X-axis. Figure 3 shows a sensor origin 5.

[0024] In aspects of the invention and with prior art techniques, the velocity and the yaw rate of the host vehicle is assumed known. The host over the ground (OTG) velocity vector is defined as:

$$V_h = [u_h \quad v_h]^T$$

55 [0025] Where u_h - host longitudinal velocity and v_h - host lateral velocity

[0026] Sensor mounting position and boresight angle in the vehicle coordinate system are also assumed known; the following notations are used:

EP 3 415 945 A1

$x_{s,VCS}$ - sensor mounting position, longitudinal coordinate
 $y_{s,VCS}$ - sensor mounting position, lateral coordinate
 $\gamma_{s,VCS}$ - sensor boresight angle

5 **[0027]** The sensor(s) Over the Ground (OTG) velocities are assumed known (determined from host vehicle motion and sensor mounting positions).

[0028] Sensor velocity vector is defined as $V_s = [u_s \ v_s]^T$ with u_s - sensor longitudinal velocity and v_s - sensor lateral velocity

10 **[0029]** At each radar measurement instance, the radar unit/sensor captures m raw detections from the target. Each raw detection is described by the following parameters expressed in the sensor coordinate system

: r_i - range (or radial distance), θ_i - azimuth angle, \dot{r}_i - raw range rate (or radial velocity) $i = 1, \dots, m$

[0030] Target planar motion is described by the Target over-the-ground velocity vector at the location of each raw detection:

15
$$V_{t,i} = [u_{t,i} \ v_{t,i}]^T$$

where:

20 $u_{t,i}$ - longitudinal velocity at the location of i -th raw detection

$v_{t,i}$ - lateral velocity at the location of i -th raw detection

Target planar motion can be described as well by:

25
$$V_{t,COR} = [\omega_t \ x_{t,COR} \ y_{t,COR}]^T$$

ω_t - target yaw rate

$x_{t,COR}$ - longitudinal coordinate of the center of target's rotation

$y_{t,COR}$ - lateral coordinate of the center of target's rotation

30 $x_{t,C}$ - longitudinal coordinate of the center of target's bounding box

$y_{t,C}$ - lateral coordinate of the center of target's bounding box

γ_t - orientation of the target object

35 **[0031]** Figure 4 illustrates how to calculate velocity vectors at the locations of three raw detections (depicted by reference numeral 6) captured from the same rigid body target and the yaw rate of that target. Center of the target's rotation depicted with reference numeral 7. The range rate equation for a single raw detection is given as follows:

40
$$\dot{r}_i + u_s \cos \theta_i + v_s \sin \theta_i = u_{t,i} \cos \theta_i + v_{t,i} \sin \theta_i$$

[0032] To simplify the notation, the notion of a compensated range rate is introduced and defined as:

45
$$\dot{r}_{i,cmp} = \dot{r}_i + u_s \cos \theta_i + v_s \sin \theta_i$$

[0033] With:

$\dot{r}_{i,cmp}$ - range rate compensated of i -th raw detection

50 **[0034]** Then the equation is reduced to:

$$\dot{r}_{i,cmp} = u_{t,i} \cos \theta_i + v_{t,i} \sin \theta_i$$

55 **[0035]** Range rate equation in vector form

$$\dot{r}_{i,\text{cmp}} = [\cos \theta_i \quad \sin \theta_i] \begin{bmatrix} u_{t,i} \\ v_{t,i} \end{bmatrix}$$

5 [0036] Range rate equation in general vector form

$$\dot{r}_{i,\text{cmp}} = [\cos \theta_i \quad \sin \theta_i] \begin{bmatrix} c_t \\ s_t \end{bmatrix}$$

10

[0037] With:

c_t - longitudinal range rate equation solution
 s_t - lateral range rate equation solution

15

[0038] Velocity profile is used as range rate equation solution synonym.

[0039] Note estimated values are denoted with a hat and Least Square solutions are denoted with a tilde.

Problem formulation

20

[0040] The problem to be solved can be phrased as follows: estimate velocity vectors $\hat{V}_{t,i}$ and yaw rate $\hat{\omega}_t$ using raw detection measurements $[r_i, \theta_i, \dot{r}_i]$ captured from a rigid body target in a single radar measurement instance.

[0041] Since the locations of the three raw detections are known (by means of direct measurements and sensor mounting position), the equivalent problem formulation is: estimate the position of the center of rotation $[\hat{x}_{t,COR}, \hat{y}_{t,COR}]$ and yaw rate $\hat{\omega}_t$ using raw detection measurements $[r_i, \theta_i, \dot{r}_i]$ captured from a rigid body target in a single radar measurement instance.

25

Prior art

30

Cloud Algorithm

[0042] Previously the case of a straight-line moving distributed target was considered. This restriction simplifies the estimation problem as the velocity vectors at the location of each raw detections are identical, i.e.:

35

$$V_{t,i} = [u_{t,i} \quad v_{t,i}]^T = [u_t \quad v_t]^T = V_t \quad \text{for} \quad i = 1, \dots, m$$

[0043] The Cloud Algorithm (CA) was proposed to estimate over-the-ground lateral v_t and longitudinal u_t velocity of the "cloud" of detections coming from the same target.

40

[0044] This was achieved by Least Square solution to the problem defined as follows:

$$\dot{r}_i = [\cos \theta_i \quad \sin \theta_i] \begin{bmatrix} u_t \\ v_t \end{bmatrix}$$

45

[0045] The algorithm proved to be a very effective technique for instantaneous estimation of target velocity. Additionally, under the additional assumption of a negligible sideslip, the angle

50

$$\hat{\gamma}_t = \tan^{-1}(\tilde{v}_t/\tilde{u}_t)$$

can be used as an estimate of the targets heading.

[0046] In D. Kellner, M. Barjenbruch, K. Dietmayer, J. Klappstein, and J. Dickmann, "Instantaneous lateral velocity estimation of a vehicle using Doppler radar," in Proceedings of 16th International Conference on Information Fusion, Istanbul, Turkey, 2013. The same problem and the same theoretical basis for the estimation of lateral velocity of a straight line moving object was considered. Enhancement to the Cloud Algorithm was made by means of executing RANSAC algorithm to identify outliers and executing orthogonal distance regression (ODR) to solve error-in-variables problem for the modified formulation of the original problem. This approach improved robustness of the solution in comparison to

55

the original Cloud Algorithm solution. Computational complexity and the requirement to solve an optimization problem are the major drawbacks of the proposed approach, especially when an application in a production embedded system is to be considered.

5 Cloud Algorithm Solution for Yawing Targets

[0047] Previously the application of the cloud algorithm to the estimation of target's motion without the restriction on straight-line path was investigated. Such situation is shown in Figure 4. The over-the-ground velocity vectors at the location of each detection are determined as follows:

10

$$\begin{bmatrix} u_{t,i,wcs} \\ v_{t,i,wcs} \end{bmatrix} = \begin{bmatrix} (y_{t,COR,wcs} - y_{t,i,wcs})\omega_t \\ (x_{t,i,wcs} - x_{t,COR,wcs})\omega_t \end{bmatrix}$$

15 [0048] The range rate equation for each raw detection was derived to be:

$$\dot{r}_{i,cmp} = (y_{t,COR,wcs} - y_{s,wcs})\omega_t \cos \theta_i + (x_{s,wcs} - x_{t,COR,wcs})\omega_t \sin \theta_i$$

20 [0049] It was then shown that the Least Square solution to this problem results in:

$$\tilde{u}_t = (y_{t,COR,wcs} - y_{s,wcs})\omega_t$$

25
$$\tilde{v}_t = (x_{s,wcs} - x_{t,COR,wcs})\omega_t$$

One therefore achieves:

30
$$\tilde{u}_t(x_{s,wcs} - x_{t,COR,wcs}) = \tilde{v}_t(y_{t,COR,wcs} - y_{s,wcs})$$

[0050] This is a result of a major importance. One can conclude (conclusion 1) that by considering range rates and azimuths from a cloud of detections coming from the same rigid body target and captured in a single look of a single radar, it is possible to estimate the position of the center of rotation and the yaw rate. Further (conclusion 2) it is possible to determine the line at which the center of rotation lies. This line passes through the sensor. This is shown in figure 5 which shows the result of the Cloud Algorithm for yawing targets. Calculations based on the three raw detections denoted 6 results in the line (of the centre of detection) 8 passing through the sensor and the center of rotation 7. The exact location of the centre of rotation 7 not specified by Cloud Algorithms.

35

[0051] In the results highlighted above are followed by the proposition of estimating the full motion of the target using detections captured in multiple looks (instances) of a single radar. Such an estimation is possible under the assumption of a constant yaw rate during the time of these multiple looks. It is also necessary for the host vehicle to be moving. Geometrical interpretation of this method is that one needs to find a (stationary) point of intersection of two lines passing through the (moving) sensor in multiple time instances. Because angles of the two lines are likely to be very similar (the faster the host moves the greater the angle), the approach is prone to inaccuracies.

[0052] In D. Kellner, M. Barjenbruch, J. Klappstein, Jurgen Dickmann, and K. Dietmayer, "Instantaneous full-motion estimation of arbitrary objects using dual doppler radar," in Proceedings of Intelligent Vehicles Symposium (IV), Dearborn, MI, USA, 2014, the same problem was considered and the solution to the Conclusion 1 was to take measurements from two sensors. The Conclusion 2 was not mentioned by the authors, but one supposes that the lines passing through both sensors would intersect in the center of target's rotation. The authors then applied RANSAC and ODR techniques previously presented in order to improve the robustness of the solution.

50

[0053] The drawbacks of the solution proposed above include that the target needs to be in the field-of-view of multiple sensors (in automotive radar configurations, common parts of field-of-view of multiple radars are usually small). For good accuracy and robustness of the solution a significant distance between the two sensors is desired. The scope of such installation is significantly limited by the dimensions of the host vehicle. One either needs to assume constant yaw rate between the looks of two radars or to synchronize the measurement instance of both sensors. Additional data processing applied to make the solution more robust are characterized by significant computational complexity.

55

Yaw Cloud Algorithm

[0054] The concepts reviewed so far have not assumed any motion model of the target. An Extended Kalman Filter has been formulated based on a constant turn motion model and measurement model derived from a cloud algorithm. The algorithm is called YCA (Yaw Cloud Algorithm). In the proposed formulation measurements from a single radar are considered, but the possibility of extension to multiple sensors is also highlighted.

[0055] One object in the current invention in comparison to the above, is not to use time-filtering, and not assume any underlying motion model for the target. The approach does not suffer from difficulties associated with appropriate track initialization.

Object orientation estimation

[0056] Further prior art relevant to the current concept focuses on the estimation of target orientation based on high-resolution radar, laser scanner or LiDAR measurements. These algorithms ignore the range rate measurement and focus exclusively on the locations of raw detections. Figure 6 shows an example of the determination of target orientation based on spatial distribution of raw detections. Example with three detections denoted with dots 6.

[0057] Several algorithms were proposed for such applications. They can be grouped in three main categories: Rotating Calipers based approaches; L-fit; and the Hough transform.

[0058] Additional modifications to the rotating calipers method were proposed. The accuracies reported for these algorithms based on the assessment of experimental results were about 10 degree RMS. The accuracies were shown to be dependent on the relative target orientation in SCS (sometimes called aspect angle or exposition angle).

[0059] A further simplified approach suitable for real-time executions has already been implemented for Short Range Radars. The enhancement proposed in that implementation is to treat the orientation of the tracked object associated with a considered cloud as an initial guess for instantaneous orientation estimation. Next the adjustment of the orientation is performed using the distribution of detections captured only in the current look. This approach can be treated as an optional 'hot starting' of the instantaneous orientation estimation. The results are promising in particular when the target is close to the host and a sufficient number of raw detections is available. It is noted here that the determination of target orientation in prior art is not related to the estimation of target motion.

[0060] Two branches of building blocks were identified: development of algorithms considering only azimuth and range rate measurements and development of algorithms considering only azimuth and range measurements

DESCRIPTION OF THE PREFERRED EMBODIMENTS

[0061] The invention includes provides instantaneous estimation of target planar motion from detections of a single radar look of e.g. a high resolution Doppler radar with the possibility of detecting that the target has a yaw rate above a certain threshold. It is to be noted that the "raw data" from this single radar look provides the parameters of r_i - range (or radial distance), θ_i - azimuth angle, \dot{r}_i - raw range rate (or radial velocity) for each i th point of m point detections on a rigid body. These are the parameters which are used to determine the yaw rate as well as longitudinal and lateral velocities, where $i = 1, \dots, m$. It is to be noted that the term instantaneous or single look radar data would include reflection data from a "chirp" in Doppler techniques which may scan over e.g. up to 2ms. By this known methodology range rate may be determined.

[0062] Methodology according to aspects are based on the combination of the cloud algorithm and spatial (or geometry) based estimation of object heading. In this way all three radar measurements (i.e. range, azimuth and range rate) are exploited to overcome the previously known limitations.

[0063] For the sake of convenience, the earlier presented cloud algorithm for yawing targets is now expressed in sensor coordinate system. As mentioned

[0064] In an initial step, the method comprises emitting a radar signal at a single time-point instance and determining from a plurality (m) of point radar detections measurements therefrom captured from said radar sensor unit in a said single radar measurement instance the values for each point detection of range, azimuth and range rate; $[r_i, \theta_i, \dot{r}_i]$

[0065] In the next step, estimates of range rate equation parameters (of the target) obtained by the Least Square Solution to:

$$\dot{r}_{i,cmp} = [\cos \theta_i \quad \sin \theta_i] \begin{bmatrix} C_t \\ S_t \end{bmatrix}$$

[0066] Starting with the definition of over-the-ground velocity vectors at the location of each detection with longitudinal $u_{t,i,SCS}$ and lateral velocities $v_{t,i,SCS}$ aligned along sensor axes:

$$\begin{bmatrix} u_{t,i,scs} \\ v_{t,i,scs} \end{bmatrix} = \begin{bmatrix} (y_{t,COR,scs} - y_{t,i,scs})\omega_t \\ (x_{t,i,scs} - x_{t,COR,scs})\omega_t \end{bmatrix}$$

5 [0067] The range rate equation becomes:

$$\dot{r}_{i,cmp} = (y_{t,COR,scs} - y_{t,i,scs})\omega_t \cos \theta_i + (x_{t,i,scs} - x_{t,COR,scs})\omega_t \sin \theta_i$$

10 [0068] Since: $y_{t,i,scs} \cos \theta_i = r_{t,i} \sin \theta_i \cos \theta_i = x_{t,i,scs} \sin \theta_i$ one can write:

$$\dot{r}_{i,cmp} = (y_{t,COR,scs})\omega_t \cos \theta_i + (-x_{t,COR,scs})\omega_t \sin \theta_i$$

15 [0069] The Least Square solution to this problem is:

$$\tilde{c}_{t,scs} = y_{t,COR,scs}\omega_t$$

$$\tilde{s}_{t,scs} = -x_{t,COR,scs}\omega_t$$

20 And:

$$\tilde{c}_{t,scs}(y_{t,COR,scs}) = \tilde{s}_{t,scs}(-x_{t,COR,scs})$$

25 [0070] It is to be noted that the range measurement is not used in velocity estimation.

30 [0071] In the next step the orientation angle of the target ($\gamma_{t,scs}$) has to be computed. This may be estimated from raw detection data such as (r_p, θ_p) and may be estimated by L fit, Hough transform or rotating caliper methodology

[0072] In the next step the line l_{PH} perpendicular to the orientation of the target and passing through the center of the target ($x_{t,c,scs}, y_{t,c,scs}$) is determined.

$$l_{PH}: y = -\frac{1}{\tan \gamma_{t,scs}} x + \frac{1}{\tan \gamma_{t,scs}} x_{t,c,scs} + y_{t,c,scs} = a_1 x + a_0$$

35 [0073] In the next step, the line l_{CA} (equivalent to reference numeral 7 of figure 5) passing through the center of rotation and sensor mounting position is determined by applying the cloud algorithm

$$l_{CA}: y = -\frac{\tilde{s}_{t,scs}}{\tilde{c}_{t,scs}} x = b_1 x + b_0$$

40 [0074] b_0 can be zero- so the term may be removed in another form of the equation.

[0075] In a fourth step the intersection point of the lines from the previous two steps are determined.

$$\hat{x}_{t,COR,scs} = \frac{b_0 - a_0}{a_1 - b_1}$$

$$\hat{y}_{t,COR,scs} = \frac{a_1 b_0 - a_0 b_1}{a_1 - b_1}$$

45 [0076] It is to be noted that if both lines are parallel (i.e. $a_1 = b_1$), then there is no solution and yaw rate cannot be estimated;

additionally: if $a_0 \neq b_0$: the lines are parallel, there is no intersection thus no yaw rate, the target is moving along a straight line and where $a_0 = b_0$: the lines are identical and nothing can be said about the motion of the target.

[0077] In step 5 if both the orientation estimation and cloud algorithm return plausible results, the yaw rate of the target calculate is calculated as:

$$\hat{\omega}_t = \frac{\tilde{s}_{t,scs}}{-\hat{x}_{t,COR,scs}}$$

10 or

$$\hat{\omega}_t = \frac{\tilde{c}_{t,scs}}{\hat{y}_{t,COR,scs}}$$

15

[0078] It is to be noted that the estimated yaw rate depends on both the Least Square result for cloud algorithm as well as the position of COR. For example, for the *same* $\tilde{s}_{t,scs}$ yaw rate will be higher when the center of rotation is calculated to be near the host vehicle and will be lower when the $\hat{x}_{t,COR,scs}$ is further away from the host. Figure 7 illustrates a geometrical interpretation of the method. Center of rotation estimated to be in the location of the dot 10.

20

Results

[0079] Results of estimating the yaw rate by the proposed technique was evaluated using experimental data. The experiments were collected for stationary host vehicle and a single target vehicle. Both vehicles were equipped with a differential GPS which accurately measures positions, velocities and yaw rates. In post-processing stage, all detections captured from the vicinity of the reference object were selected for calculating cloud algorithm. The orientation of the target was taken directly from reference data.

25

[0080] Figure 8 shows an example of test results of a maneuver which comprised the target 9 driving on a circular track 12. Figure 9a to d illustrate the movement. The point of intersection of the two lines 13 and 14 (equivalent to lines ICA and IPH respectively) remains roughly at the same position, which is consistent with the actual maneuver performed. The only exception is when the two lines are almost parallel. This confirms analytical results.

30

[0081] Figure 10 shows an example of test results of a maneuver where the target 9 is driving straight and figure 11a to d illustrates temporal movement. The two lines 13 and 14 remain parallel. This is consistent with the expected behavior, because the target is not yawing.

35

[0082] Figure 12 shows examples of test results of a maneuver where the target is maneuvering at a junction and figures 13 a to d illustrate temporal movement. The intersection point changes its position as the yaw rate of the target smoothly changes during the maneuver. This is consistent with expected behavior. Yet again, promising result for junction assist applications.

[0083] In the scenario discussed in this document, detections coming from a single sensor are considered. There are different ways detections from multiple sensors can be used when the target is in the common area of their FOVs: each sensor may estimate its own lines resulting from cloud algorithm and orientation estimation

40

[0084] In ideal case all lines should intersect at the same point, i.e. the center of rotation. Each sensor can calculate its own center of rotation. These points can then be used to determine resulting estimate for the center of rotation. Such processing should consider plausibility measures for sensor estimate. Detections from all sensors can be collected for improved orientation estimation, but each sensor can calculate a cloud algorithm result based on its own detections.

45

Using filtered heading

[0085] Estimation of object orientation usually require more detections than the execution of cloud algorithm. For the purpose of yaw rate estimation/detections, one may consider using target orientation from an associated tracker object. In such a case, yaw rate can be estimated based on only two raw detections. The yaw rate estimation is likely to be more robust, but it will not be an instantaneous result.

50

Include the proposed approach in object tracking filter

55

[0086] If instantaneous estimation is not required, one can consider formulating an object tracking filter. The measurement model of such a filter would then include estimations of yaw rate and center of rotation as proposed in this work.

Propagation of uncertainty

[0087] If the uncertainty of cloud algorithm, as well as uncertainty of orientation is known then uncertainty propagation rules can be used for uncertainty estimation of center of rotation and yaw rate. It can be the most efficient way to determinate if motion estimation is reliable. Estimated uncertainty can be also used in Kalman filter as a level of measurement noise.

[0088] In its pure form, the approach described here is not based on tracking or filtering and therefore does not require any motion model and no initialization stage is required.

[0089] The approach has a lower number of restrictions in comparison to currently known concepts based on Cloud Algorithm. It does not need measurements from several time instances and works for stationary host vehicle. It does not need the target to be in the field of view of two sensors mounted significant distance away from each other. The approach does not require filtering/tracking and does not rely on any target motion model. The algorithm is suitable for application in production embedded systems because of its low computational complexity. The method can be immediately used in state-of-art short range radars for estimation of objects at low range (up to about 15 meters); e.g. it is suitable for junction assist applications (crossroads, roundabouts). The accuracy of the results can only be improved if more detections from moving objects were available; this is likely to happen as sensing technology progresses and in sensors dedicated to Autonomous Driving applications.

Claims

1. A method of determining the yaw rate ($\hat{\omega}_t$) of a target vehicle in a horizontal plane by a host vehicle equipped with a radar system, said radar system including a radar sensor unit adapted to receive signals emitted from said host vehicle by said target, comprising:

- a) emitting a radar signal at a single time-point instance and determining from a plurality (m) of point radar detections measurements captured from said target vehicle by said radar sensor unit in said single radar measurement instance, the values for each point detection of range, azimuth and range rate; [r_p, θ_p, \dot{r}_p]
- b) determining the values of the longitudinal and lateral components of the range rate equation of the target (ct, st) from the results (\dot{r}_i, θ_i) of step a); where the range rate equation is

$$\dot{r}_{i,cmp} = [\cos \theta_i \quad \sin \theta_i] \begin{bmatrix} c_t \\ s_t \end{bmatrix}$$

where $\dot{r}_{i,cmp} = \dot{r}_i + u_s \cos \theta_i + v_s \sin \theta_i$ where u_s is the sensor unit or host vehicle longitudinal velocity and v_s is the sensor unit or host vehicle lateral velocity;

- c) determining the orientation angle of the target ($\gamma_{t,scs}$);
- d) determining the target centre (x_t and y_t) from the results (r_p, θ_p) of step a);
- e) determining a line l_{PH} perpendicular to the orientation of the target and passing through the center of the target ($x_{t,c,scs}, y_{t,c,scs}$) from the results of step (c) and (d);
- f) determining a line l_{CA} passing through the center of rotation of said target and the position of radar sensor unit of said vehicle; from the steps of b)
- g) determining the intersection point of the lines l_{CA} and l_{PH} from steps e) and f) being the position of the center of rotation [$\hat{x}_{t,COR}, \hat{y}_{t,COR}$] of the target;
- h) estimating and yaw rate $\hat{\omega}_t$ from the position of the centre of rotation found in step g) and components of range rate equation of the target (ct or st) of step b).

2. A method as claimed in claim 1 wherein said step c) comprises determining the orientation angle of the target ($\gamma_{t,scs}$); from the values of range and azimuth (r_p, θ_p) of said point detections.

3. A method as claimed in claim 1 or 2 where step c) comprises determining the orientation angle of the target ($\gamma_{t,scs}$); from L fit, Hough transform or rotating caliper methodology from the results of step a).

4. A method as claimed in claims 1 to 3 where step b) includes estimating components of range rate equation of the target (c_t, s_t) said point detection measurements of azimuth and range rate [θ_p, \dot{r}_p].

5. A method as claimed in claim 4 wherein said estimating comprises applying a Least Square method.

6. A method as claimed in claims 1 to 5 wherein said line l_{PH} of step e) is determined and defined from the following equation:

$$y = -\frac{1}{\tan \gamma_{t,scs}} x + \frac{1}{\tan \gamma_{t,scs}} x_{t,c,scs} + y_{t,c,scs} = a_1 x + a_0$$

7. A method as claimed in claims 1 to 6 wherein said line l_{CA} of step f) is determined and defined from the following equation

$$y = -\frac{\tilde{S}_{t,scs}}{\tilde{C}_{t,scs}} x = b_1 x + b_0$$

8. A method as claimed in claims 1 to 7 where in step g) the position of the center of rotation $[\hat{x}_{t,COR}, \hat{y}_{t,COR}]$ of the target is determined from the following equations:

$$\hat{x}_{t,COR,scs} = \frac{b_0 - a_0}{a_1 - b_1} \quad \text{and,} \quad \hat{y}_{t,COR,scs} = \frac{a_1 b_0 - a_0 b_1}{a_1 - b_1}$$

9. A method as claimed in claims in 1 to 8 where in step h) the yaw rate is determined from the following equations:

$$\hat{\omega}_t = \frac{\tilde{S}_{t,scs}}{-\hat{x}_{t,COR,scs}}$$

or

$$\hat{\omega}_t = \frac{\tilde{C}_{t,scs}}{\hat{y}_{t,COR,scs}}$$

10. A method as claimed in claims 1 to 9 including additionally determining estimates of longitudinal velocity $\hat{u}_{t,i}$, lateral velocity $\hat{v}_{t,i}$ of certain target point from the value of yaw rate and the co-ordinates of the centre of rotation of the target ($y_{t,COR,wcs}$ $x_{t,COR,wcs}$) using the following equation;

$$\begin{bmatrix} \hat{u}_{t,i,scs} \\ \hat{v}_{t,i,scs} \end{bmatrix} = \begin{bmatrix} (\hat{y}_{t,COR,scs} - y_{t,i,scs}) \hat{\omega}_t \\ (x_{t,i,scs} - \hat{x}_{t,COR,scs}) \hat{\omega}_t \end{bmatrix}$$

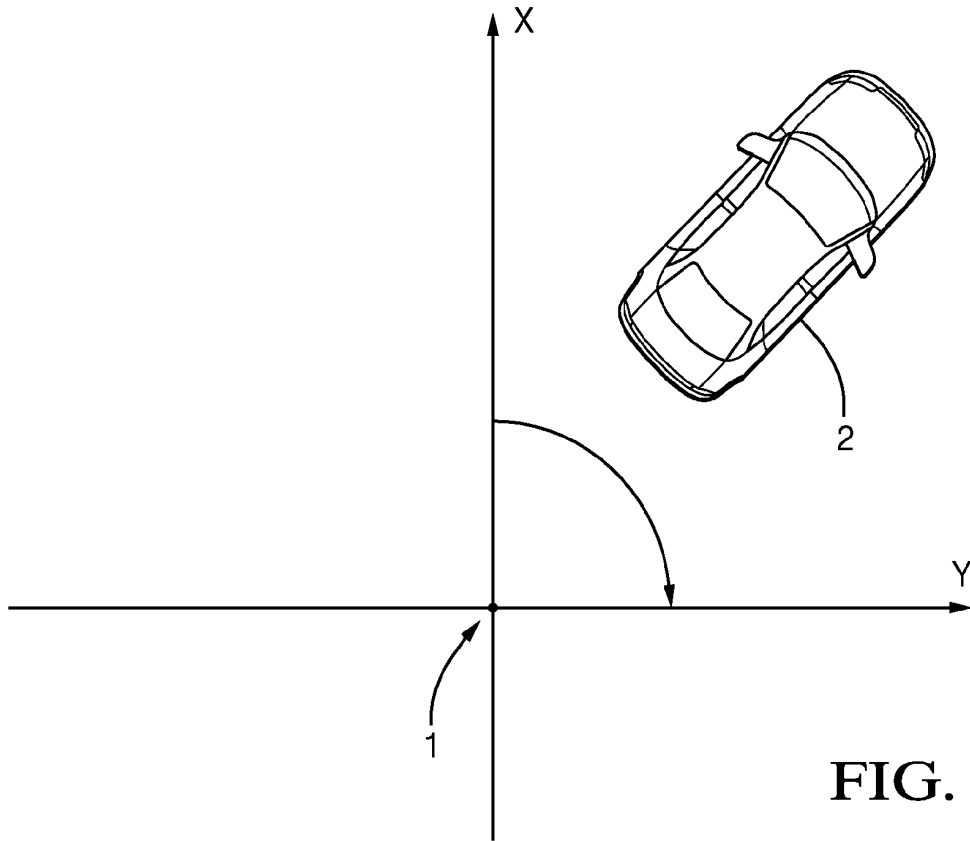

FIG. 1

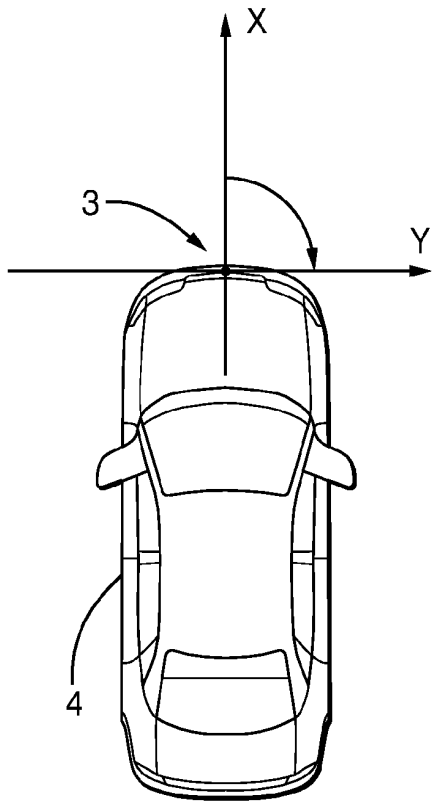

FIG. 2

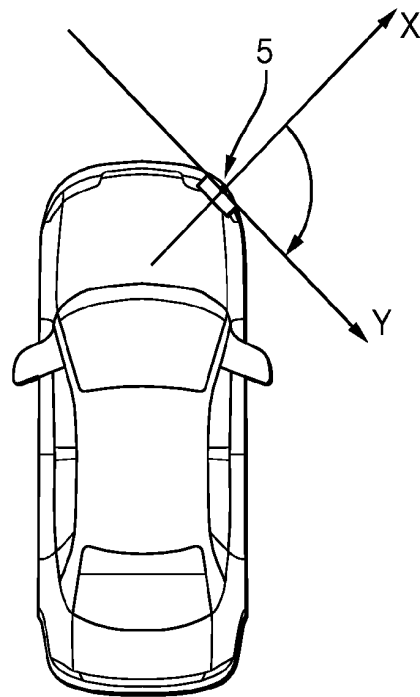

FIG. 3

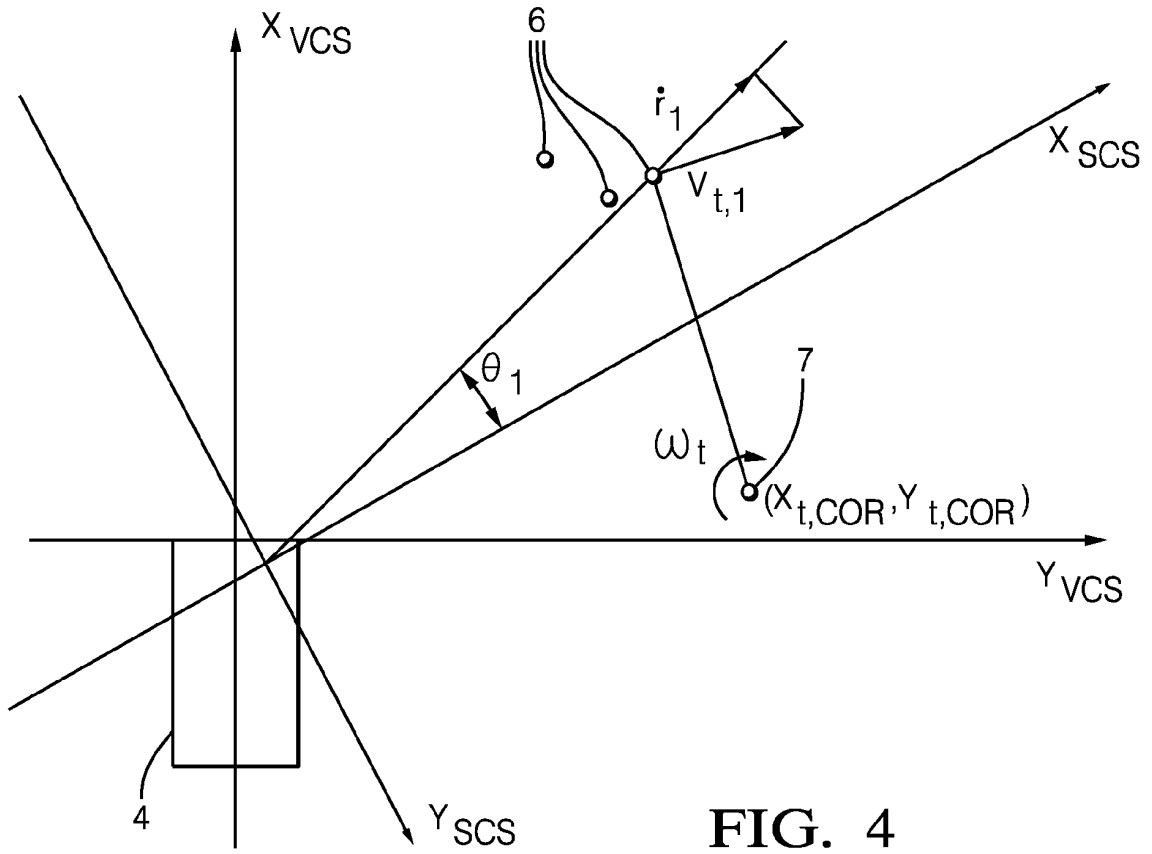

FIG. 4

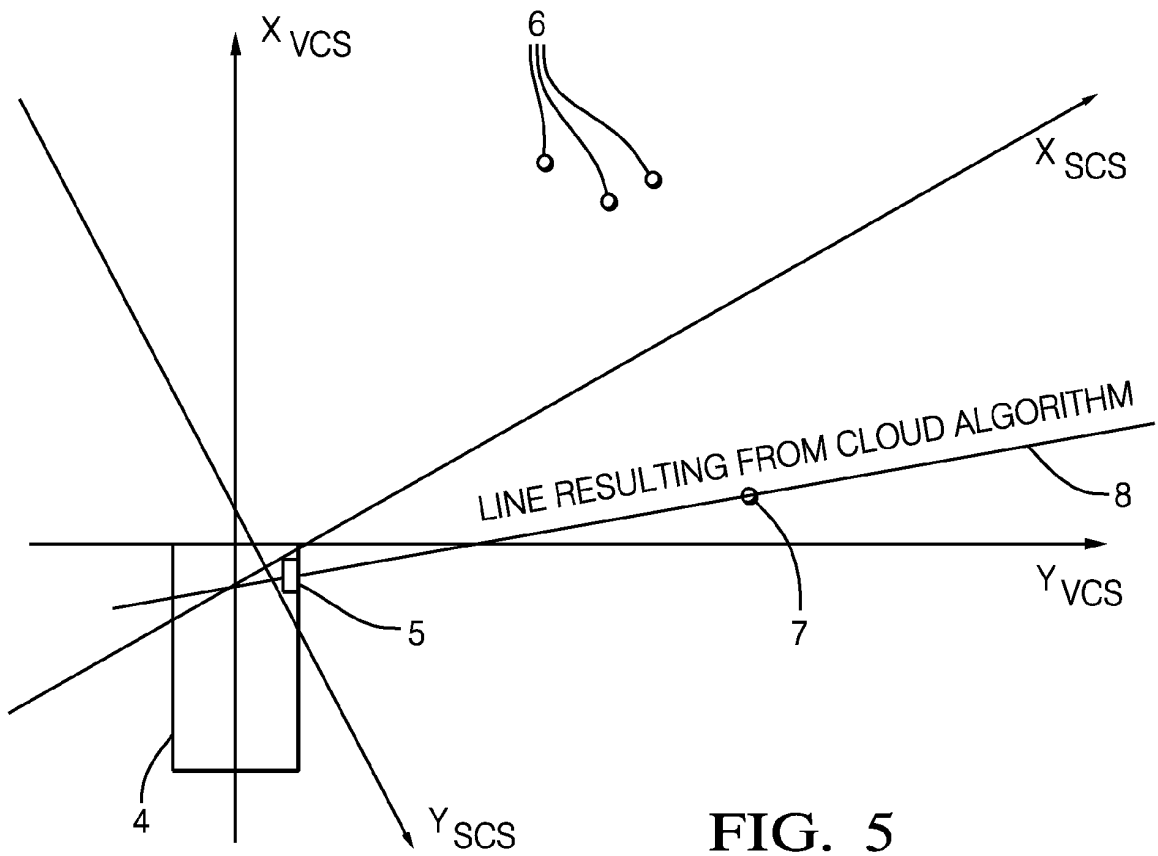

FIG. 5

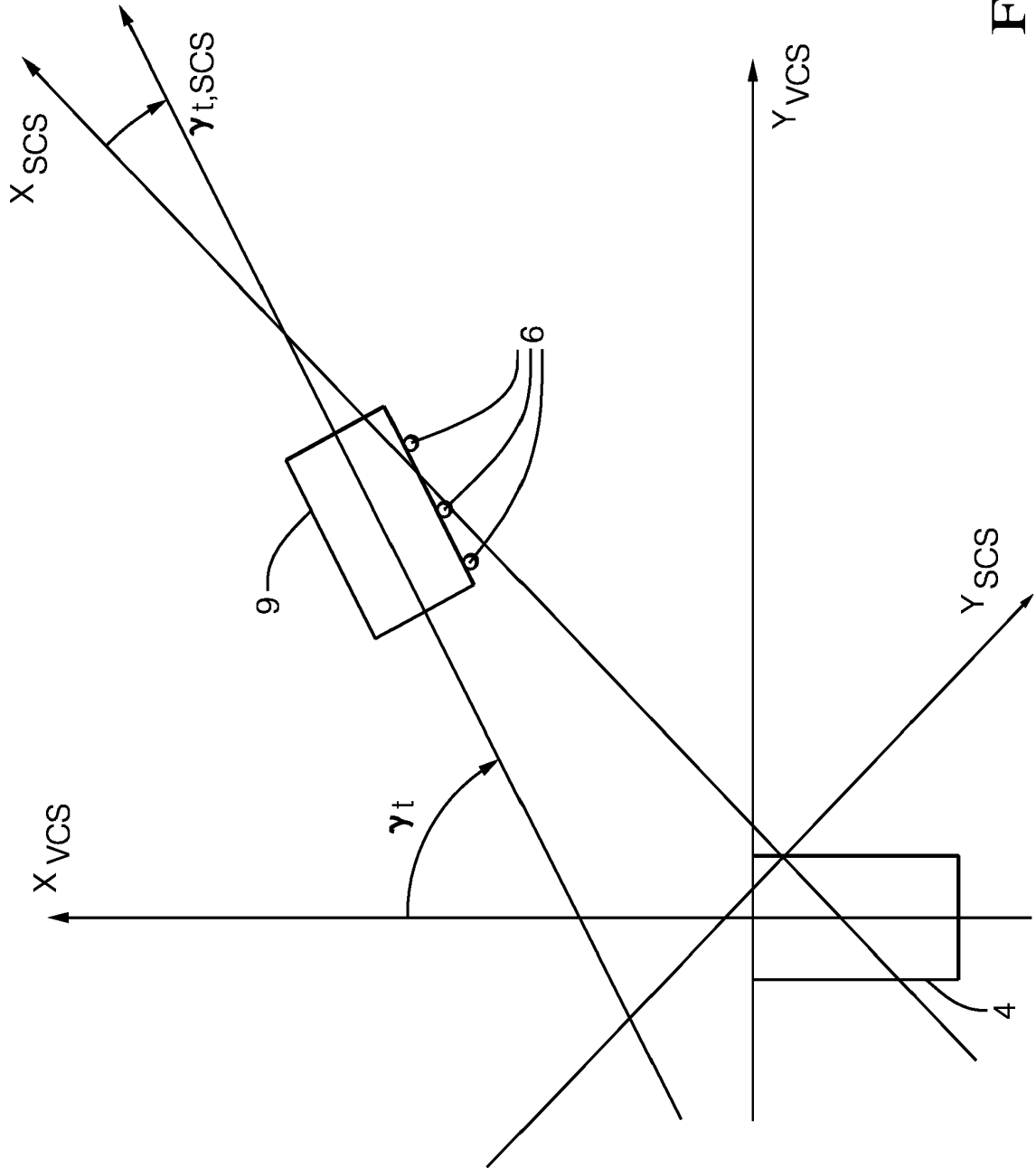

FIG. 6

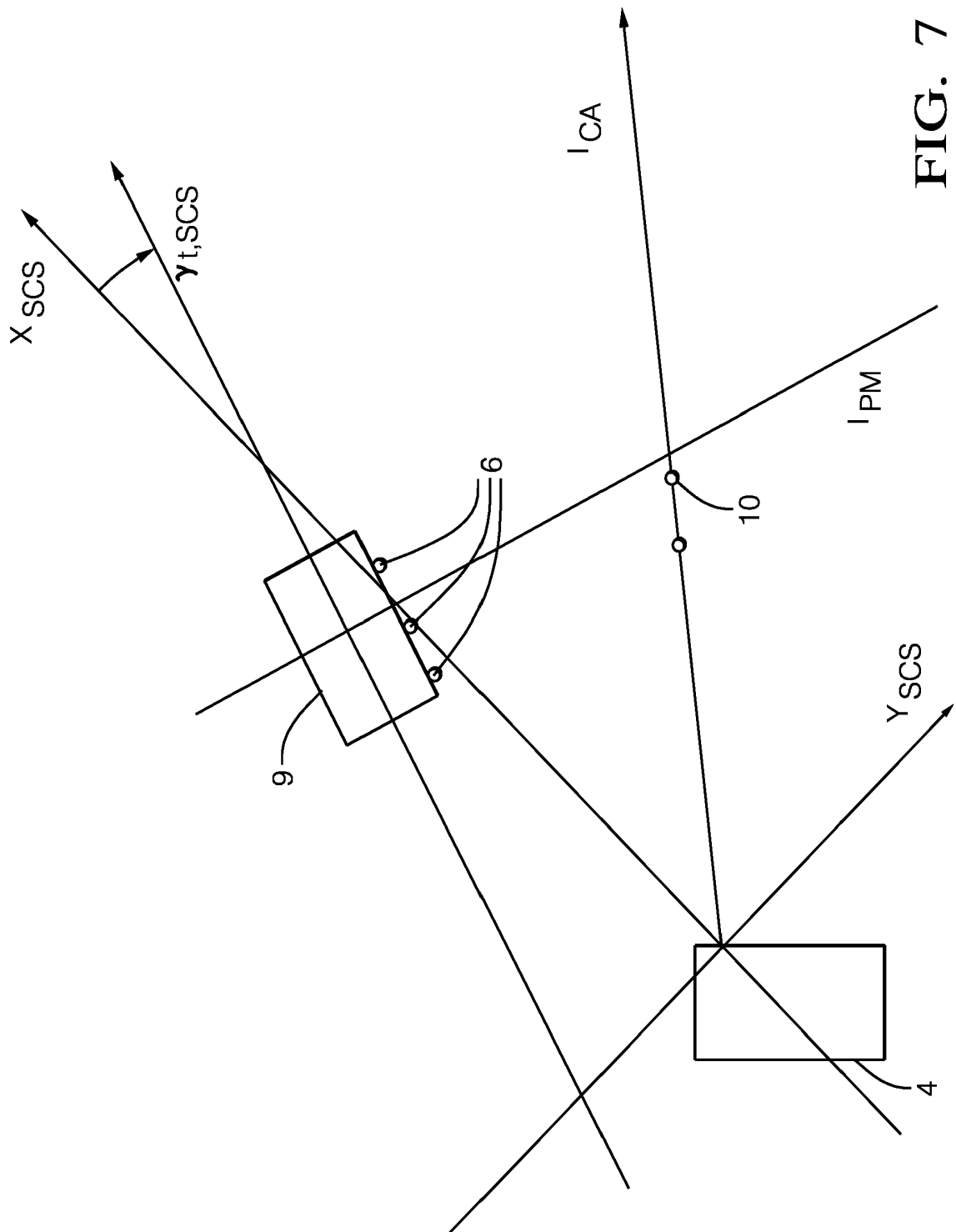

FIG. 7

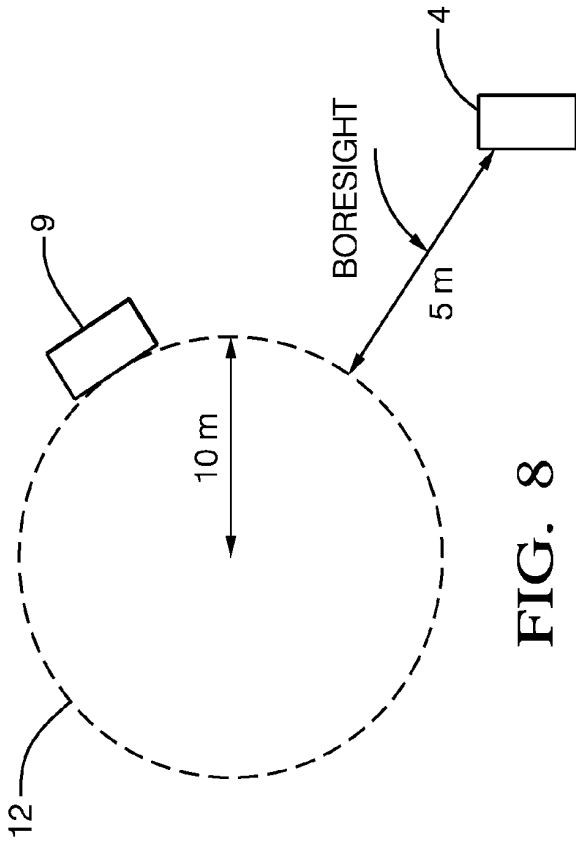

FIG. 8

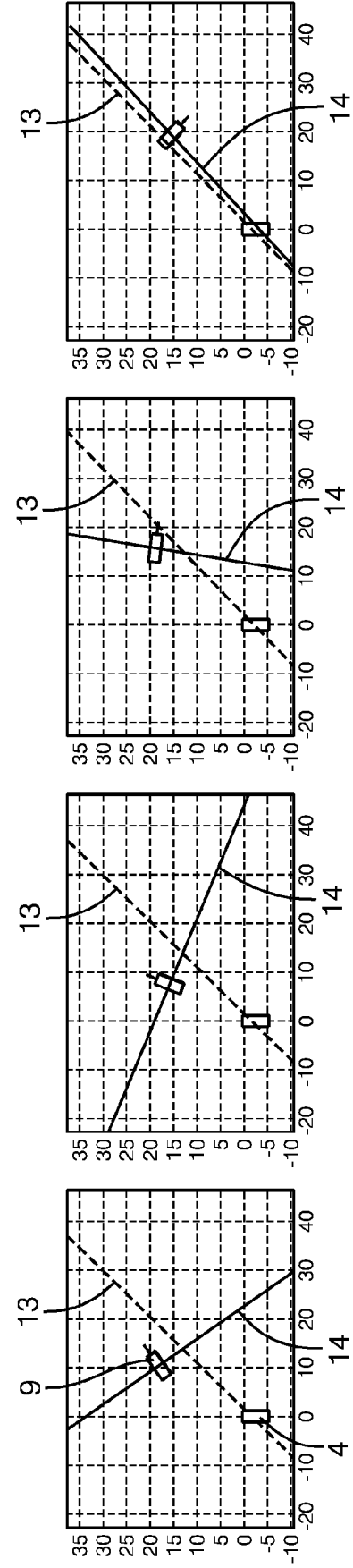

FIG. 9a

FIG. 9b

FIG. 9c

FIG. 9d

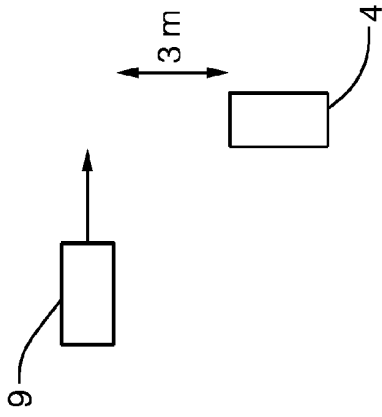

FIG. 10

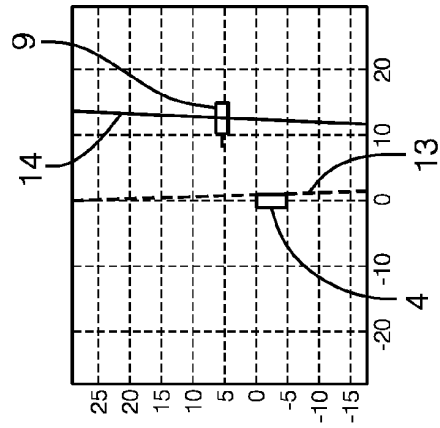

FIG. 11a

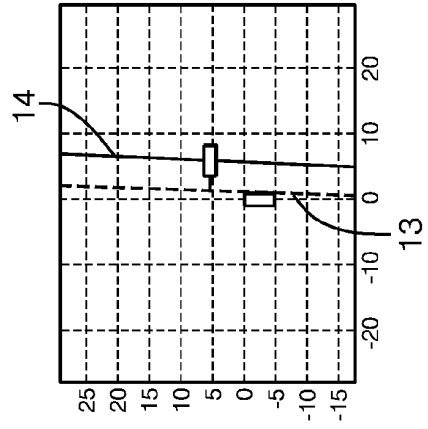

FIG. 11b

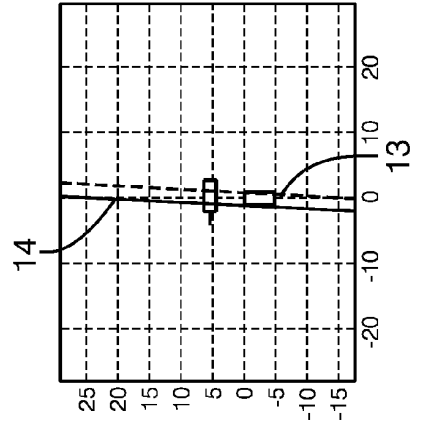

FIG. 11c

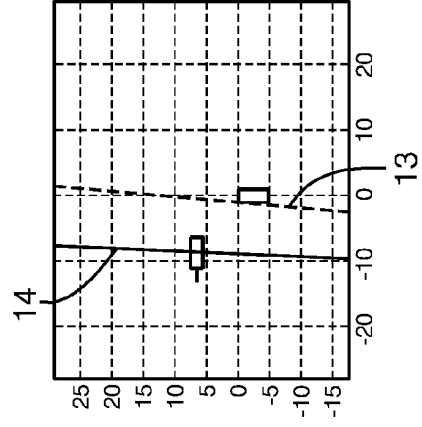

FIG. 11d

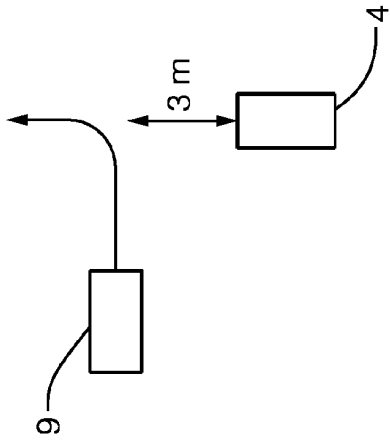

FIG. 12

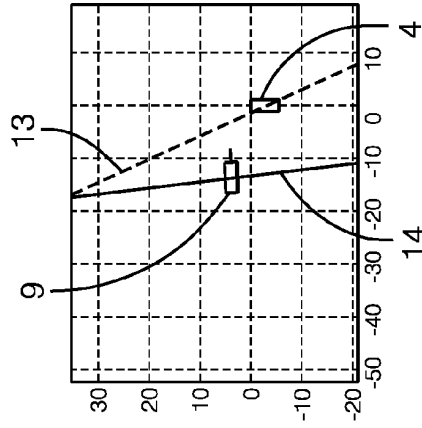

FIG. 13a

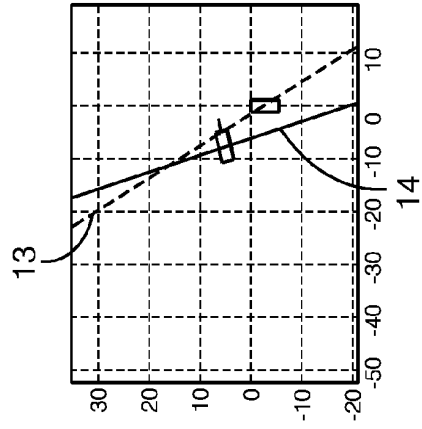

FIG. 13b

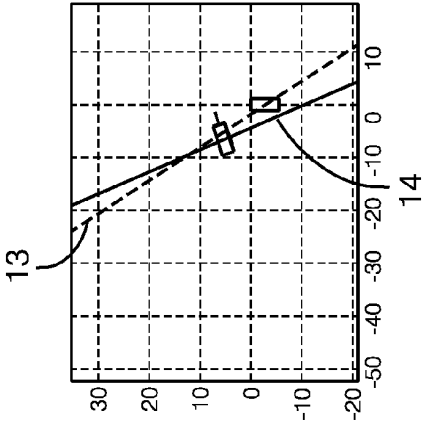

FIG. 13c

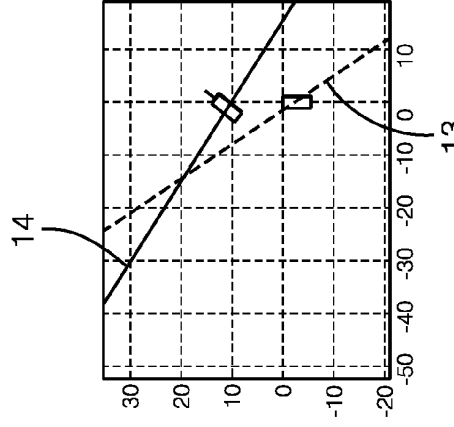

FIG. 13d



EUROPEAN SEARCH REPORT

Application Number
EP 17 17 5548

5

10

15

20

25

30

35

40

45

DOCUMENTS CONSIDERED TO BE RELEVANT			
Category	Citation of document with indication, where appropriate, of relevant passages	Relevant to claim	CLASSIFICATION OF THE APPLICATION (IPC)
X	<p>KELLNER DOMINIK ET AL: "Tracking of Extended Objects with High-Resolution Doppler Radar", IEEE TRANSACTIONS ON INTELLIGENT TRANSPORTATION SYSTEMS, IEEE, PISCATAWAY, NJ, USA, vol. 17, no. 5, 1 May 2016 (2016-05-01), pages 1341-1353, XP011608058, ISSN: 1524-9050, DOI: 10.1109/TITS.2015.2501759 [retrieved on 2016-04-29]</p> <p>* paragraphs [II.B], [IV.A]; figure 4 * & KELLNER DOMINIK ET AL: "Instantaneous full-motion estimation of arbitrary objects using dual Doppler radar", 2014 IEEE INTELLIGENT VEHICLES SYMPOSIUM PROCEEDINGS, IEEE, 8 June 2014 (2014-06-08), pages 324-329, XP032620317, DOI: 10.1109/IVS.2014.6856449 [retrieved on 2014-07-15]</p> <p>* paragraph [II.A] - paragraph [II.D] *</p> <p>-----</p>	1-10	<p>INV. G01S13/58 G01S13/93</p> <p>ADD. G01S7/295</p>
A	<p>ROOS FABIAN ET AL: "Estimation of the orientation of vehicles in high-resolution radar images", 2015 IEEE MTT-S INTERNATIONAL CONFERENCE ON MICROWAVES FOR INTELLIGENT MOBILITY (ICMIM), IEEE, 27 April 2015 (2015-04-27), pages 1-4, XP032783377, DOI: 10.1109/ICMIM.2015.7117949 [retrieved on 2015-06-03]</p> <p>* paragraphs [II.B], [IV.A] *</p> <p>-----</p>	2,3	<p>TECHNICAL FIELDS SEARCHED (IPC)</p> <p>G01S</p>
A	<p>DE 10 2013 019804 A1 (DAIMLER AG [DE]) 28 May 2015 (2015-05-28)</p> <p>* paragraphs [0023] - [0039] *</p> <p>-----</p>	1-10	
2 The present search report has been drawn up for all claims			
Place of search Munich		Date of completion of the search 7 December 2017	Examiner Ferrara, Michele
CATEGORY OF CITED DOCUMENTS		<p>T : theory or principle underlying the invention E : earlier patent document, but published on, or after the filing date D : document cited in the application L : document cited for other reasons</p> <p>..... & : member of the same patent family, corresponding document</p>	
<p>X : particularly relevant if taken alone Y : particularly relevant if combined with another document of the same category A : technological background O : non-written disclosure P : intermediate document</p>			

EPO FORM 1503 03.02 (P04001)

55

**ANNEX TO THE EUROPEAN SEARCH REPORT
ON EUROPEAN PATENT APPLICATION NO.**

EP 17 17 5548

5

This annex lists the patent family members relating to the patent documents cited in the above-mentioned European search report. The members are as contained in the European Patent Office EDP file on
The European Patent Office is in no way liable for these particulars which are merely given for the purpose of information.

07-12-2017

10

Patent document cited in search report	Publication date	Patent family member(s)	Publication date
DE 102013019804 A1	28-05-2015	NONE	

15

20

25

30

35

40

45

50

55

EPO FORM P0459

For more details about this annex : see Official Journal of the European Patent Office, No. 12/82

REFERENCES CITED IN THE DESCRIPTION

This list of references cited by the applicant is for the reader's convenience only. It does not form part of the European patent document. Even though great care has been taken in compiling the references, errors or omissions cannot be excluded and the EPO disclaims all liability in this regard.

Non-patent literature cited in the description

- **D. KELLNER ; M. BARJENBRUCH ; K. DIETMAYER ; J. KLAPPSTEIN ; J. DICKMANN.** Instantaneous lateral velocity estimation of a vehicle using Doppler radar. *Proceedings of 16th International Conference on Information Fusion, Istanbul, 2013* [0046]
- **D. KELLNER ; M. BARJENBRUCH ; J. KLAPPSTEIN ; JURGEN DICKMANN ; K. DIETMAYER.** Instantaneous full-motion estimation of arbitrary objects using dual doppler radar. *Proceedings of Intelligent Vehicles Symposium (IV), 2014* [0052]